

## Features

- Gain: 28dB Typical
- Noise Figure: 2.0dB Typical
- P1dB Output Power: +23dBm Typical
- Supply Voltage: +12V
- 50 Ohm Matched



## Typical Applications

- Wireless Infrastructure
- 5G communication
- Test and measurement Instrument

RF Microwave & VSAT  
Fiber Optics

| Parameter                                     | Min. | Typ. | Max. | Min. | Typ. | Max. | Min. | Typ. | Max. | Units |
|---|------|------|------|------|------|------|------|------|------|-------|
| Frequency Range                               | 0.05 |      | 0.2  | 0.2  |      | 10   | 10   |      | 20   | GHz   |
| Gain  | 27   | 30   | 34   | 27   | 29   | 33   | 25   | 27   | 31   | dB    |
| Gain Flatness                                 |      | ±1.0 |      |      | ±1.0 | ±1.5 |      | ±1.5 | ±2.0 | dB    |
| Gain Variation Over Temperature (-40°C~+85°C) |      | ±0.5 |      |      | ±1.0 |      |      | ±2.0 |      | dB    |
| Noise Figure                                  |      | 4.0  |      |      | 2.0  | 4.0  |      | 2.5  | 4.5  | dB    |
| Input VSWR                                    |      | 3    |      |      | 1.8  | 2    |      | 1.8  | 2    | : 1   |
| Output VSWR                                   |      | 1.5  |      |      | 1.5  | 1.8  |      | 1.5  | 1.8  | : 1   |
| Output 1dB Compression Point (P1dB)           |      | 22   |      | 21   | 23   |      | 19   | 21   |      | dBm   |
| Saturated Output Power (Psat)                 |      | 24   |      |      | 25   |      |      | 23   |      | dBm   |
| Output Third Order Intercept (OIP3)           |      | 30   |      |      | 32   |      |      | 30   |      | dBm   |
| Supply Current (Vcc=+12V)                     |      | 260  | 350  |      | 260  | 350  |      | 260  | 350  | mA    |
| Isolation S12                                 |      | -60  |      |      | -65  |      |      | -60  |      | dB    |

|                           |                     |                    |                 |                                |
|---------------------------|---------------------|--------------------|-----------------|--------------------------------|
| Weight                    | Net                 | 0.45 ounces (Max.) | Impedance       | 50ohms                         |
|                           | Including Heat sink | 2.2 ounces (Max.)  |                 |                                |
| Input / Output Connectors | SMA-Female          |                    | Material        | Aluminum                       |
| Finish                    | Gold Plated         |                    | Package Sealing | Epoxy Sealed (Standard)        |
|                           |                     |                    |                 | Hermetically Sealed (Optional) |

**SALUKI TECHNOLOGY INC.**

Ultra Wide Band Low Noise Amplifier 0.05GHz ~ 20GHz

**Absolute Maximum Ratings**

|                       |       |
|-----------------------|-------|
| Operating Voltage     | +15V  |
| RF Input Power (RFIN) | +4dBm |

**Biasing Up Procedure**

|        |                          |
|--------|--------------------------|
| Step 1 | Connect Ground Pin       |
| Step 2 | Connect input and output |
| Step 3 | Connect +12V biasing     |

**Power OFF Procedure**

|        |                       |
|--------|-----------------------|
| Step 1 | Turn off +12V biasing |
| Step 2 | Remove RF connection  |
| Step 3 | Remove Ground         |

**Environmental Specifications**

|                         |  |
|-------------------------|--|
| Operational Temperature | -40°C~+85°C  |
| Storage Temperature     | -50°C~+105°C   |
| Altitude                | 30,000 ft. (Epoxy Sealed Controlled environment)                                 |
|                         | 60,000 ft. 1.0psi min (Hermetically Sealed Un-controlled environment) (Optional) |
| Vibration               | 25g RMS (15 degrees 2KHz) endurance, 1 hour per axis                             |
| Humidity                | 100% RH at 35°C, 95%RH at 40°C   |
| Shock                   | 20G for 11msec half sine wave, 3 axis both directions                            |

**Outline Drawing:**

All Dimensions in mm (inches)

Heat Sink required during operation(Sold Separately)

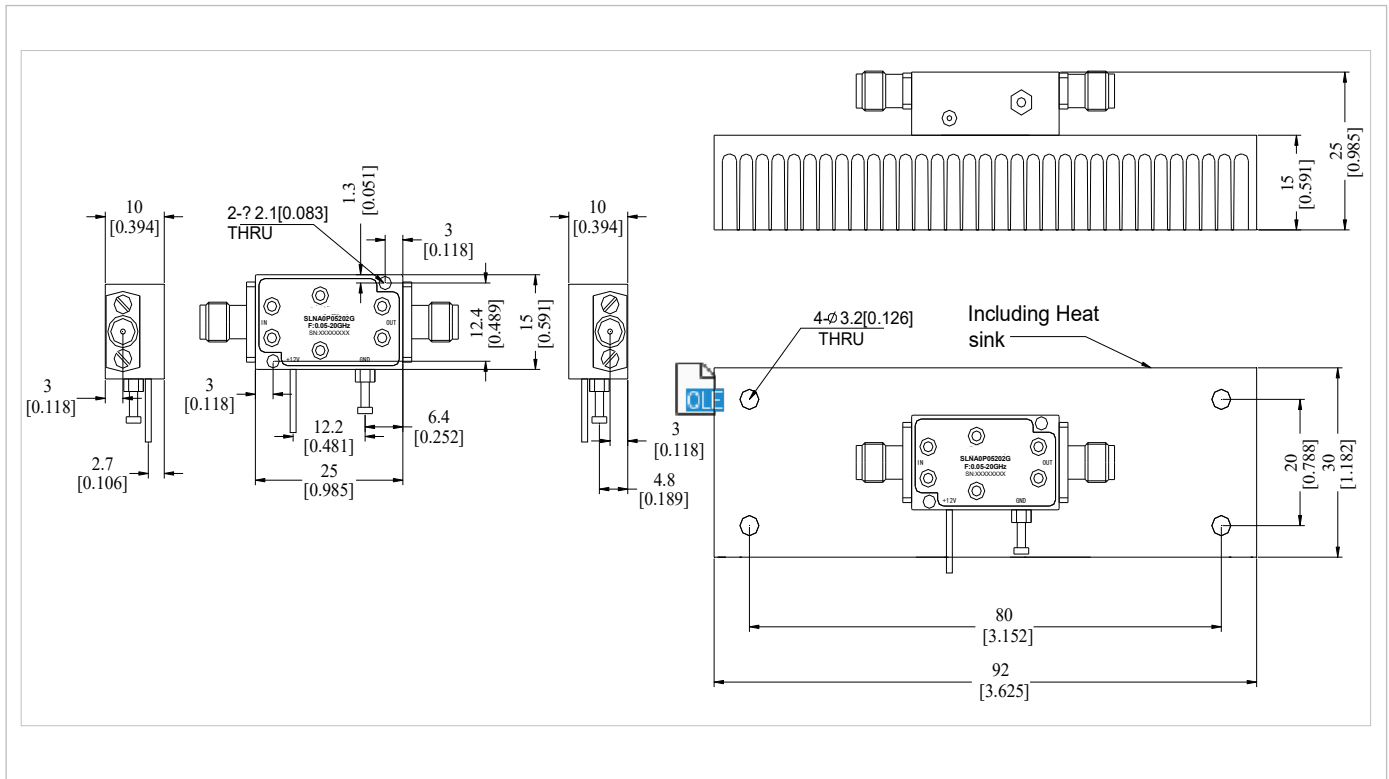

**SALUKI TECHNOLOGY INC.**  
Gain @+25°C

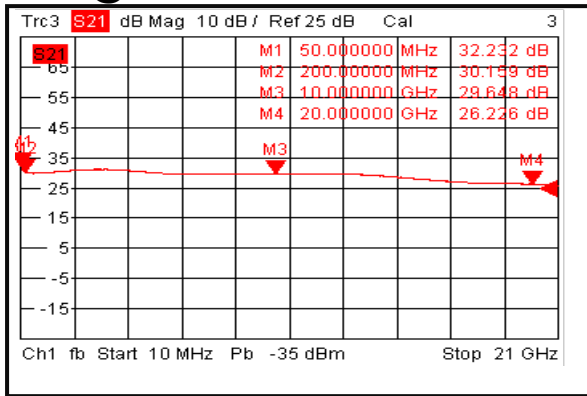

Ultra Wide Band Low Noise Amplifier 0.05GHz ~ 20GHz  
Input VSWR @+25°C

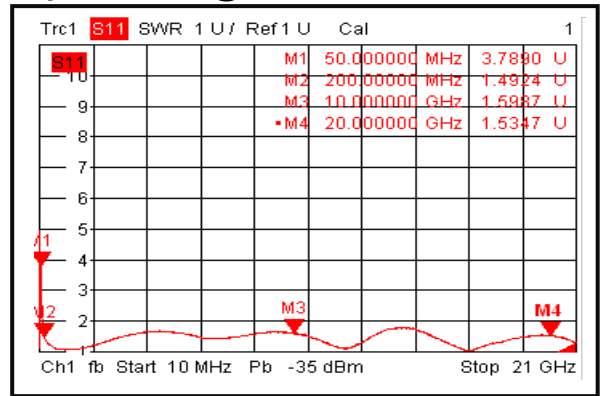

Output VSWR @+25°C

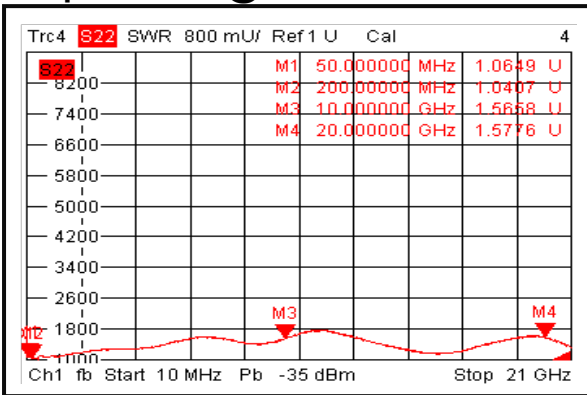

Isolation @+25°C

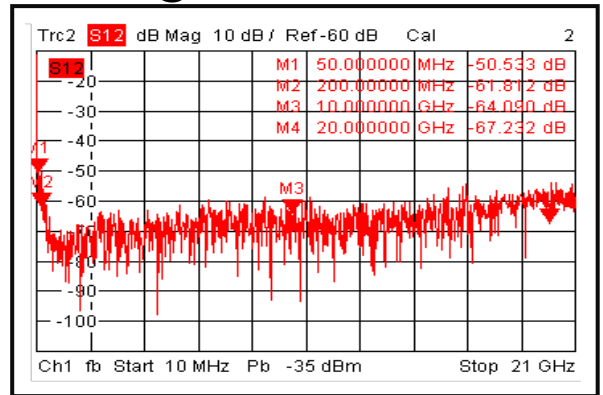

Gain @-40°C

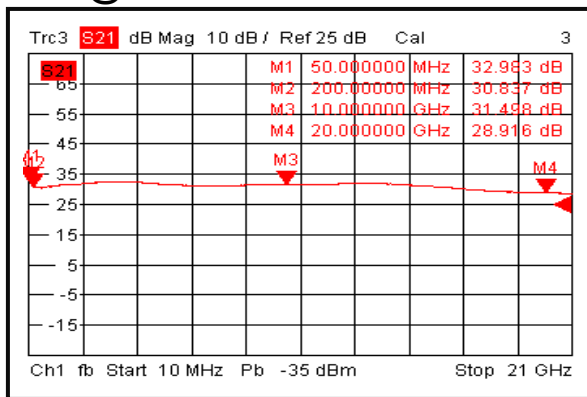

Input VSWR @-40°C

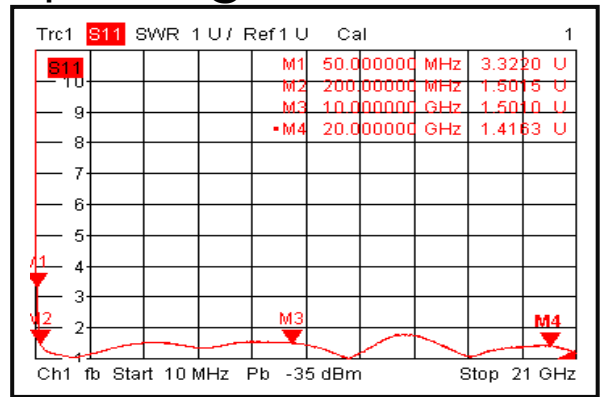

Output VSWR @-40°C

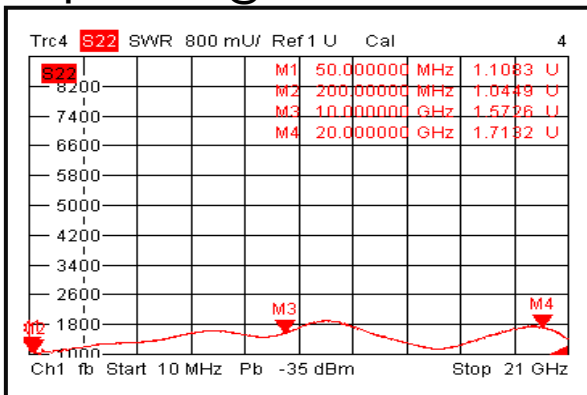

Isolation @-40°C

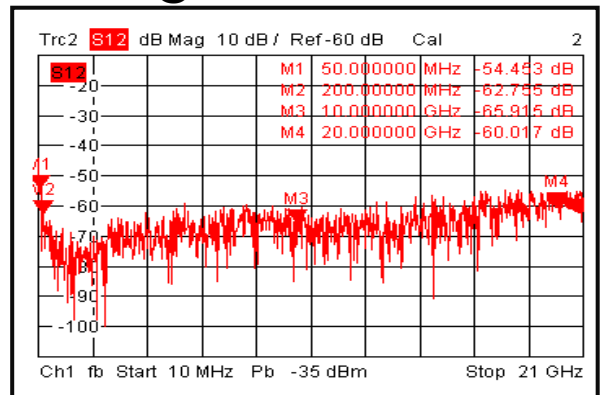

**SALUKI TECHNOLOGY INC.**  
Gain @+85°C

Ultra Wide Band Low Noise Amplifier 0.05GHz ~ 20GHz  
Input VSWR @+85°C

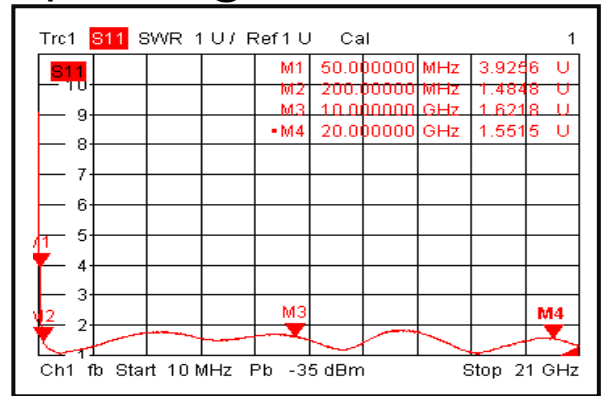
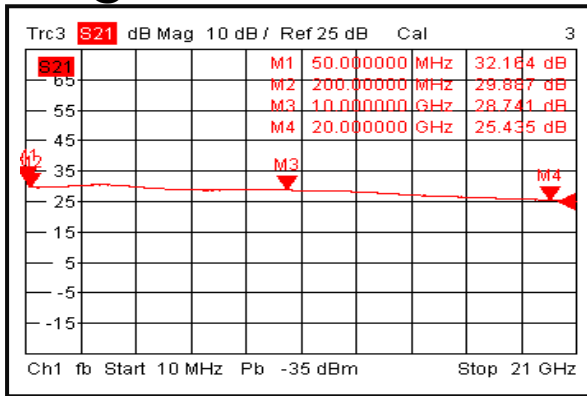

Output VSWR @+85°C

Isolation @+85°C

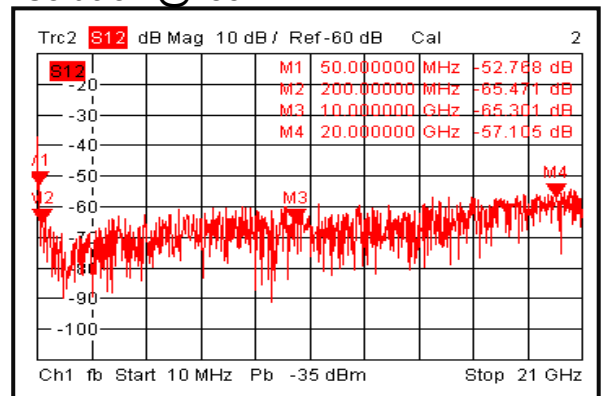
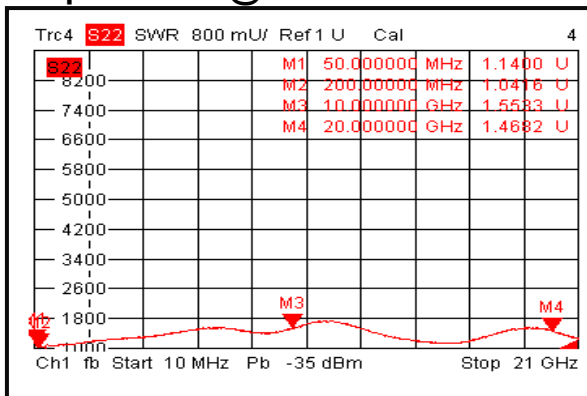

Gain vs. Output Power

P1dB vs. Frequency

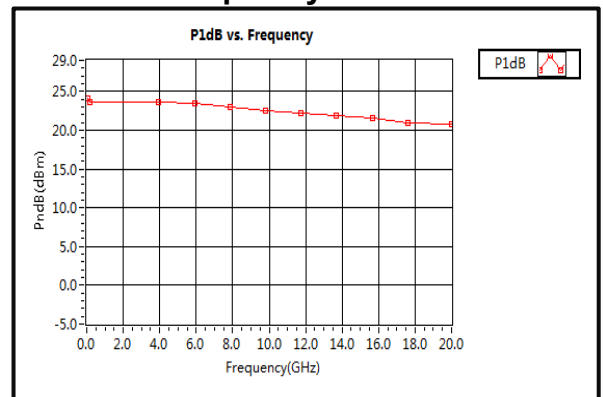
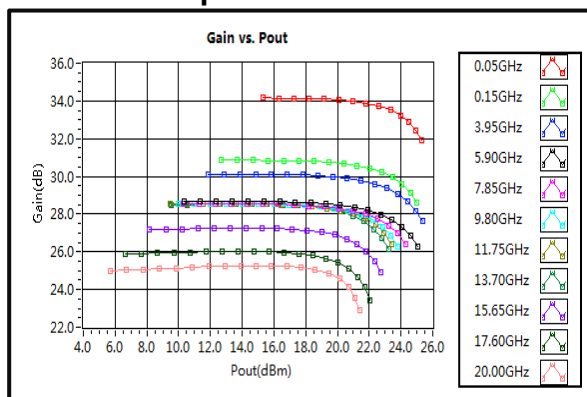

Output Third Order Intercept (OIP3)

Saturation Power vs. Frequency

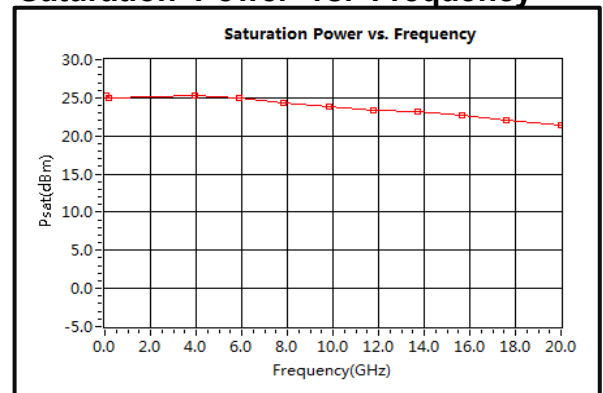
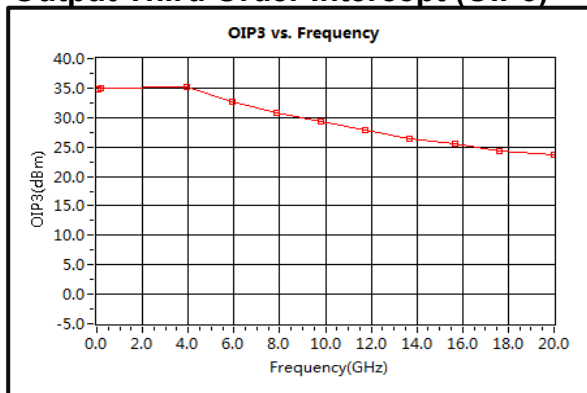

**Noise Figure(50MHz-200MHz)**

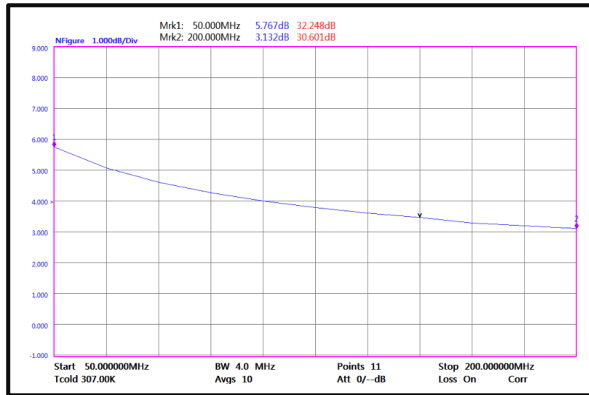

**Noise Figure(200MHz-4GHz)**

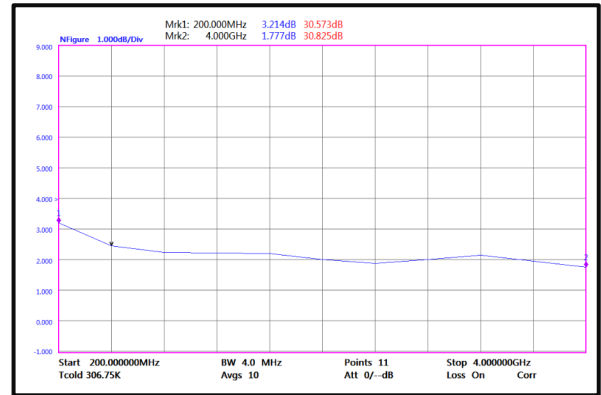

**Noise Figure(4GHz-20GHz)**

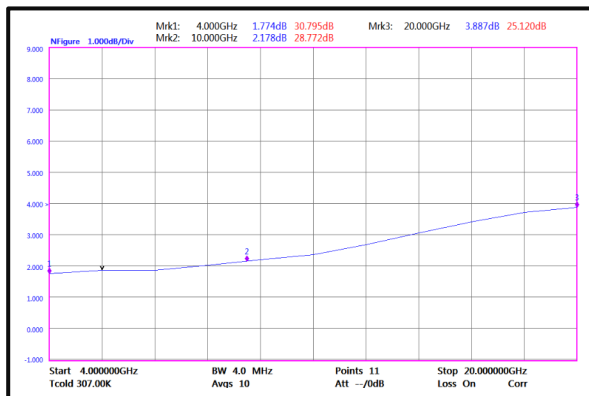

**2nd Harmonic Wave Output Power**

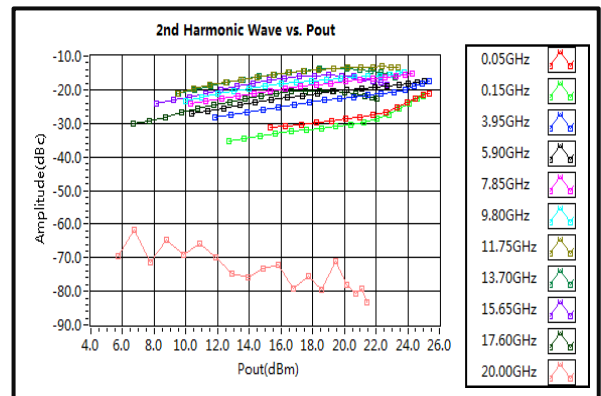

**3rd Harmonic Wave Output Power**

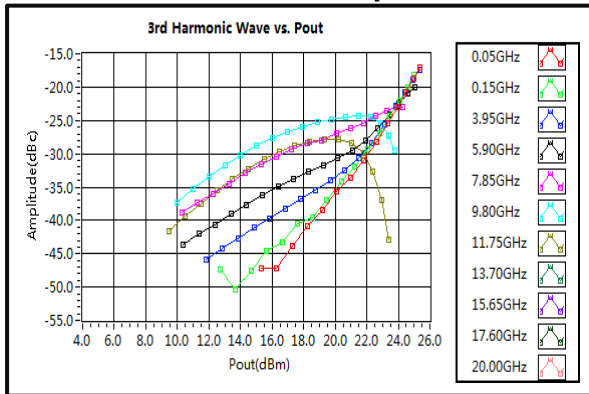

**4th Harmonic Wave Output Power**

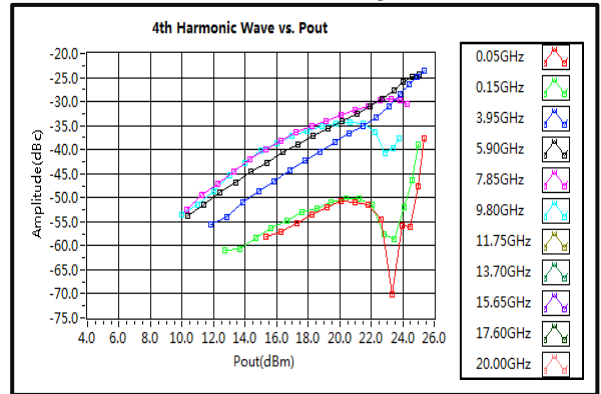

Saluki and its affiliates reserve the right to make changes to the product(s) or information contained herein without notice. Visit [www.salukitec.com](http://www.salukitec.com) for additional datasheets and product information.