

Features

- High Output Power 25dBm Typical.
- High peak to average handling capability.
- High linearity and low noise figure.
- Convenient AC Power Input. (AC 110V/220V)
- Integrated Heat Sink and Fan.

Typical Applications

- Wireless Infrastructure
- 5G communication
- Test and measurement Instrument

 RF Microwave & VSAT
 Fiber Optics

Parameter	Min.	Typ.	Max.	Min.	Typ.	Max.	Units
Frequency Range	0.1		10	10		20	GHz
Gain	17.5	18.5		17.5	19		dB
Gain Flatness		±1.0	±2.0		±1.0	±2.0	dB
Gain Variation Over Temperature (-40°C~+85°C)		±1.0			±1.5		dB
Noise Figure		3.0			4.0		dB
Input VSWR		1.3			1.8		: 1
Output VSWR		1.5			2.0		: 1
Output 1dB Compression Point (P1dB)	22	24		18	21		dBm
Saturated Output Power (Psat)		25			23		dBm
Output Third Order Intercept (OIP3)		33			28		dBm
Supply Current (AC =220V)		55			55		mA
Isolation S12		-65			-55		dB

Weight	40 Max.ounces	Impedance	50ohms
Input /Output Connectors	SMA-Female	Material	Aluminum
Finish	Gray Painted		

Wide Band AC-Low Noise Amplifier 0.1GHz~20GHz

Absolute Maximum Ratings

Supply Voltage	110V to 240V AC
RF Input Power(RFIN)	+23dBm

Note: Maximum RF input power is defined to protect the amplifier from damage.
 Input power may be increased at the users own risk to achieve the full output power of the amplifier. Please reference gain and power curves and monitor the temperature.

Biassing Up Procedure

Step 1	Connect input and output with 50 Ohm source and load with in band return loss better than 10dB.
Step 2	Connect AC Plug
Step 3	Flip switch to "ON" position

Power OFF Procedure

Step 1	Flip switch to "OFF" position
Step 2	Remove AC Plug
Step 3	Remove RF Connection

Environmental Specifications

Operational Temperature	-40°C~+85°C(Case Temperature)
Storage Temperature	-50°C~+105°C
Altitude	30,000 ft. (Epoxy Sealed Controlled environment)
	60,000 ft. 1.0psi min (Hermetically Sealed Un-controlled environment) (Optional)
Vibration	25g RMS (15 degrees 2KHz) endurance, 1 hour per axis
Humidity	100% RH at 35°C, 95%RH at 40°C
Shock	20G for 11msec half sine wave,3 axis both directions

Outline Drawing:

All Dimensions in mm (inches)
 Housing Tolerances ± 1.5 (0.06)

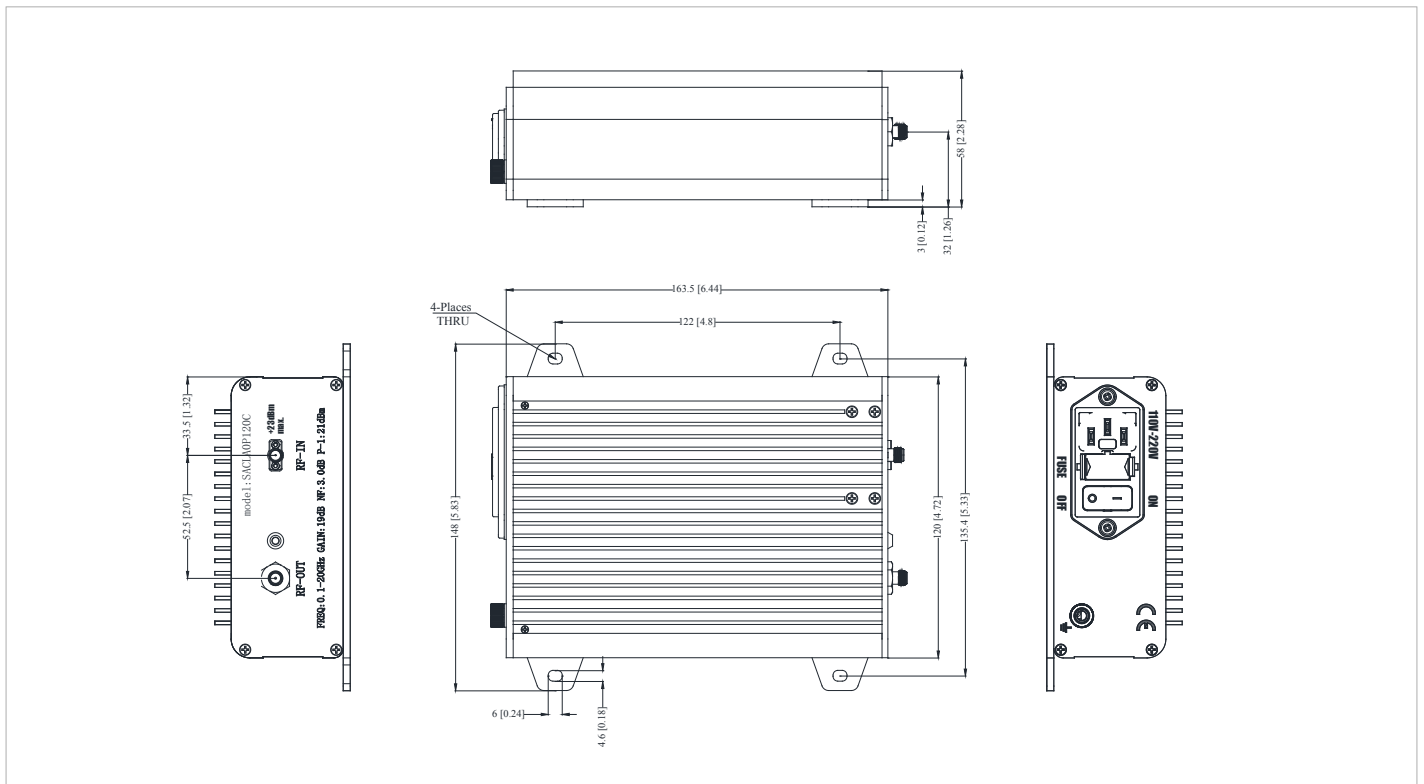

Wide Band AC-Low Noise Amplifier 0.1GHz~20GHz

Gain@+25°C

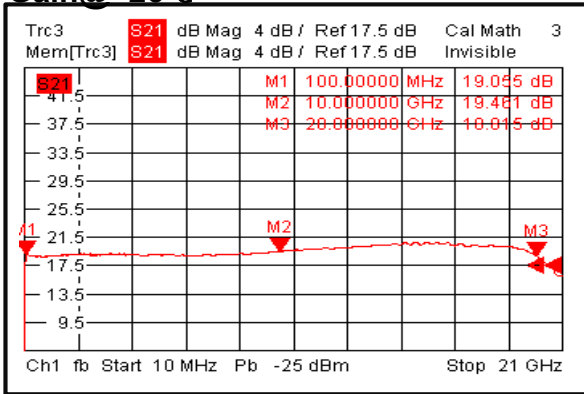

Input VSWR@+25°C

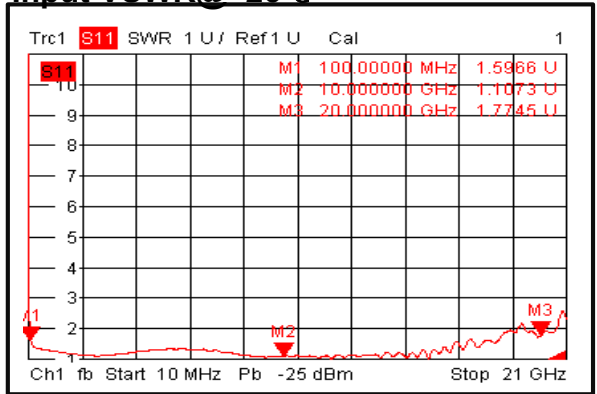

Output VSWR@+25°C

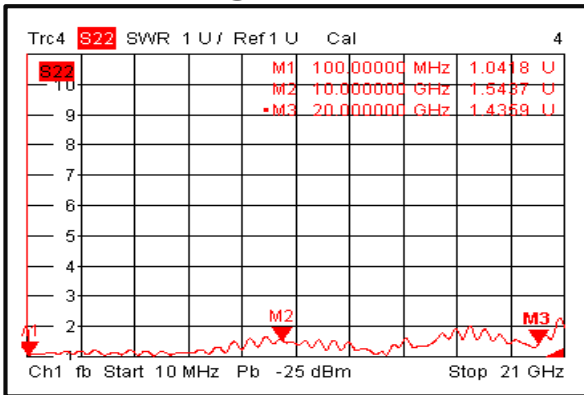

Isolation@+25°C

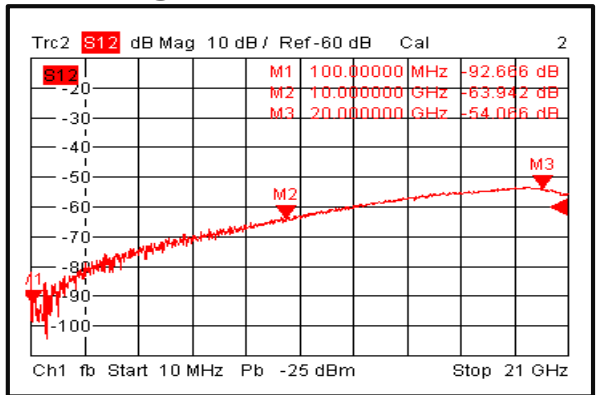

Gain@-40°C

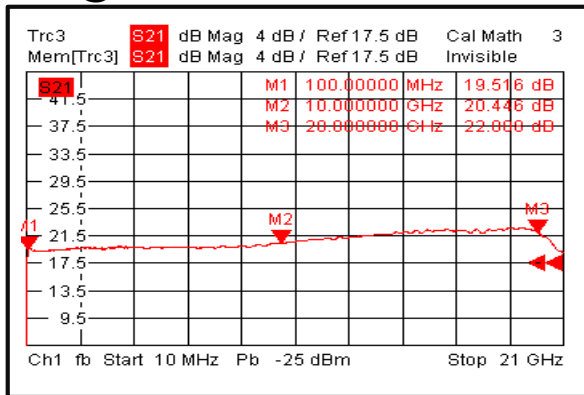

Input VSWR @-40°C

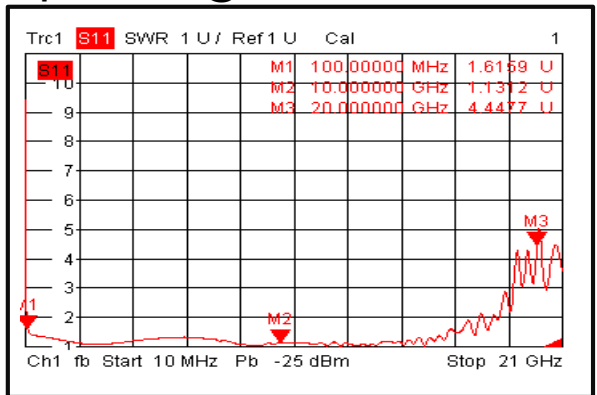

Isolation@-40°C

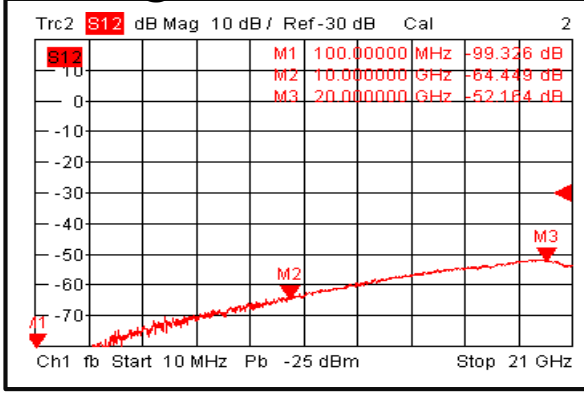

Gain @+85°C

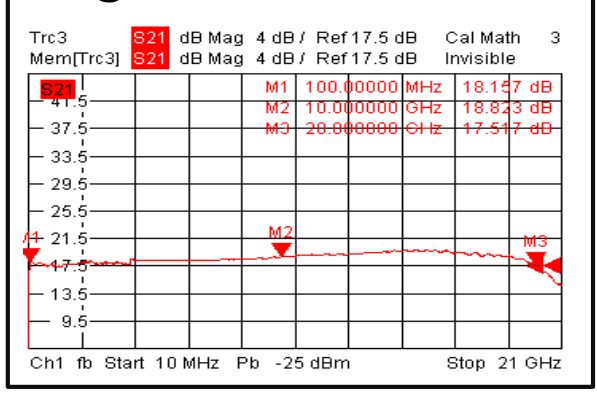

**Wide Band AC-Low Noise Amplifier 0.1GHz~20GHz
Isolation@+85°C**

Input VSWR@+85°C

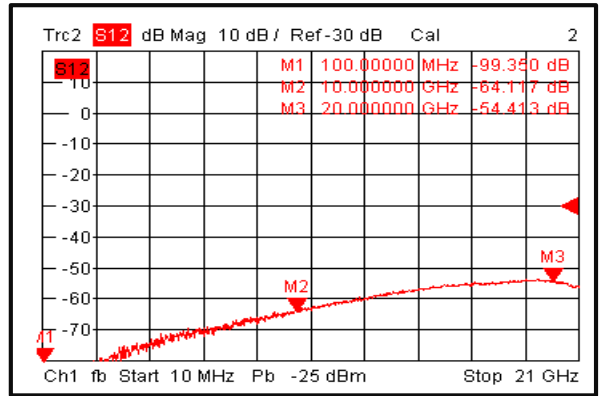
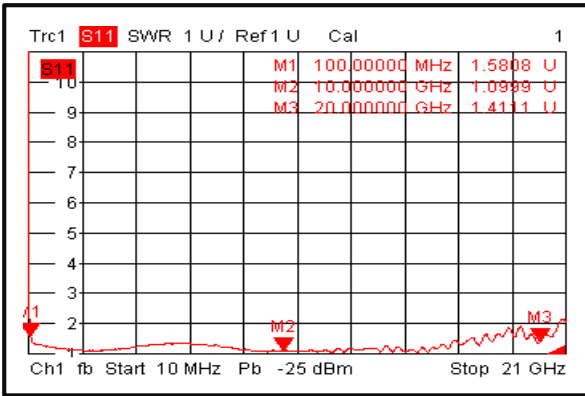

Gain vs. Output Power

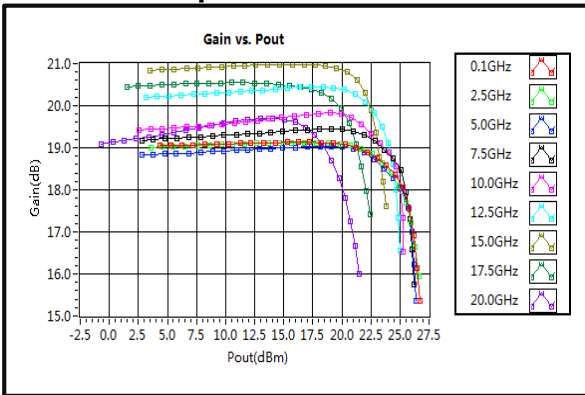

PndB vs. Frequency

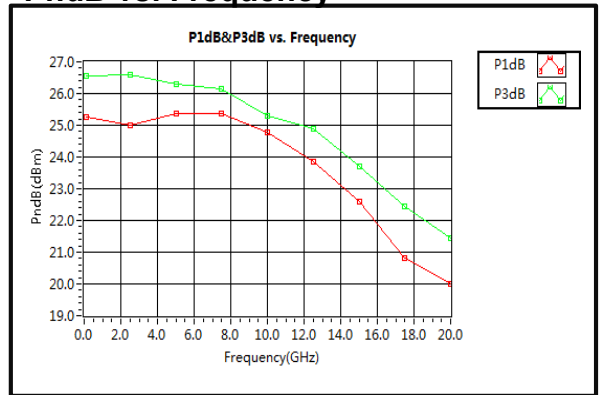

Saturated Power vs. Frequency

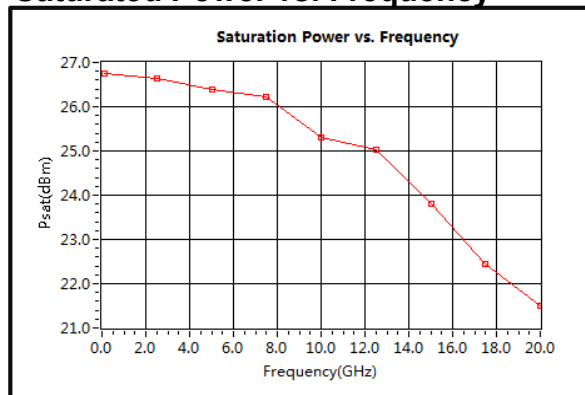

OIP3 vs. Frequency

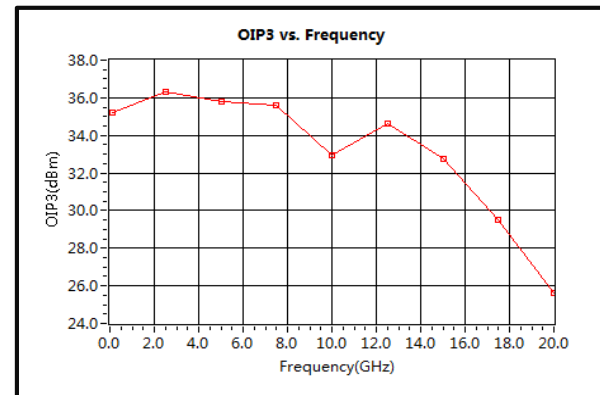

Pout vs. Pin

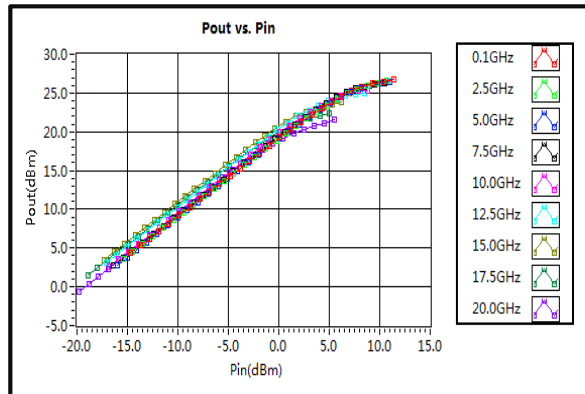

Noise Figure(0.1-4GHz)

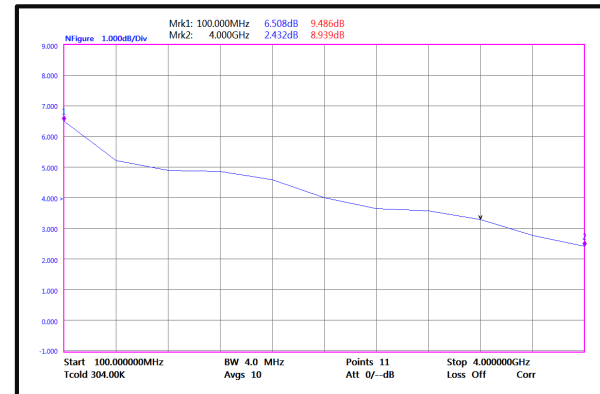

Wide Band AC-Low Noise Amplifier 0.1GHz~20GHz

Noise Figure(4-20GHz)

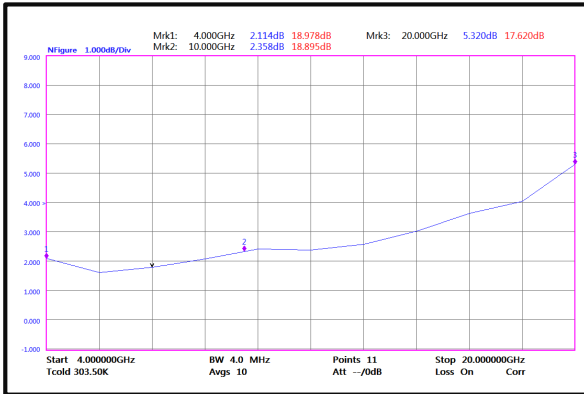

2nd Harmonic Wave Output Power

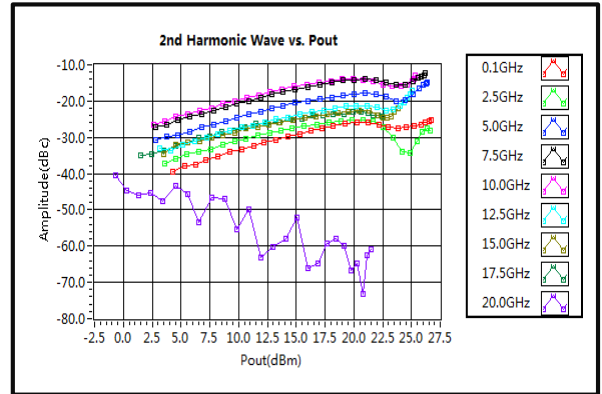

3rd Harmonic Wave Output Power

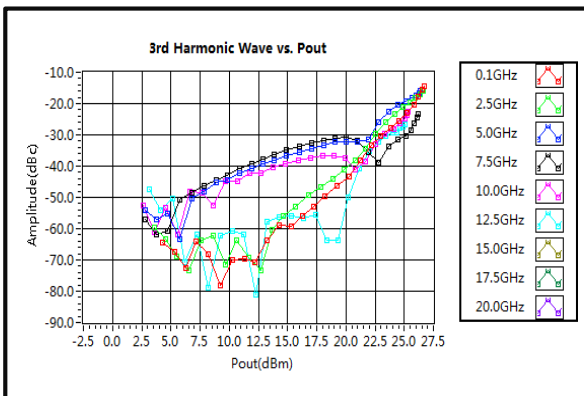

4th Harmonic Wave Output Power

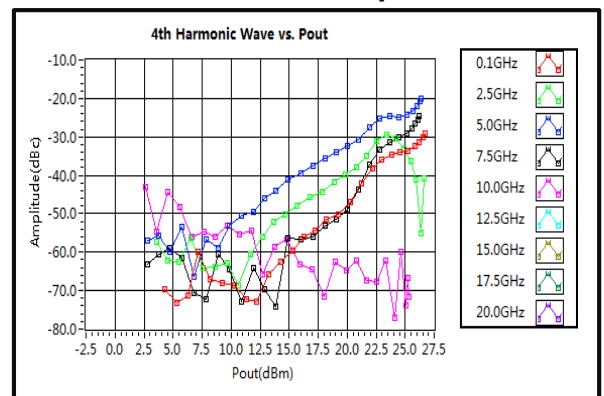

Saluki and its affiliates reserve the right to make changes to the product(s) or information contained herein without notice. Visit www.salukitec.com for additional data sheets and product information.