



# S4382 Series Microwave Frequency Counter

## User Manual



Saluki Technology Inc.

**The document applies to the microwave frequency counter of the following models:**

- S4382A microwave frequency counter (10Hz - 9GHz)
- S4382B microwave frequency counter (10Hz - 12.4GHz)
- S4382C microwave frequency counter (10Hz - 18GHz)
- S4382SD microwave frequency counter (10Hz - 20GHz)
- S4382SE microwave frequency counter (10Hz - 22GHz)
- S4382D microwave frequency counter (10Hz - 26.5GHz)
- S4382E microwave frequency counter (10Hz - 36GHz)
- S4382F microwave frequency counter (10Hz - 40GHz)

**Standard Package of the S4382 series microwave frequency counter:**

No.	Item	Qty.
1	Microwave Frequency Counter	1
2	Test Cable (BNC Q9-J5)	1
3	Test Cable (SMA OR K)	1
4	Power Line	1
5	RS232 Cable Jumper	2
6	RS232 Test Software CD	1

**Options of the S4382 series microwave frequency counter:**

Model No.	Item
S4382-01	High-stability and Constant- temperature Crystal Oscillator $5 \times 10^{-9}$ /day
S4382-02	High-stability and Constant- temperature Crystal Oscillator $3 \times 10^{-9}$ /day
S4382-03	IEEE488 general interface
S4382-04	USB general serial interface
S4382-05	Manual Measurement Module
S4382-06	LAN interface



## Preface

Thank you for choosing S4382 series microwave frequency counter produced by Saluki Technology Inc.

We devote ourselves to meeting your demands, providing you high-quality measuring instrument and the best after-sales service. We persist with “superior quality and considerate service”, and are committed to offering satisfactory products and service for our clients.

## Document No.

S4382-03-01

## Version

Rev01 2022.05

Saluki Technology

## Document Authorization

The information contained in this document is subject to change without notice. The power to interpret the contents of and terms used in this document rests with Saluki.

Saluki Tech owns the copyright of this document which should not be modified or tampered by any organization or individual, or reproduced or transmitted for the purpose of making profit without its prior permission, otherwise Saluki will reserve the right to investigate and affix legal liability of infringement.

## Product Quality Assurance

The warranty period of the product is three years from the date of delivery. The instrument manufacturer will repair or replace damaged parts according to the actual situation within the warranty period.

## Product Quality Certificate

The product meets the indicator requirements of the document at the time of delivery. Calibration and measurement are completed by the measuring organization with qualifications specified by the state, and relevant data are provided for reference.

## Quality/Settings Management

Research, development, manufacturing and testing of the product comply with the requirements of the quality and environmental management system.

## Contacts

Service Tel: 886. 909 602 109  
Website: www.salukitec.com  
Email: sales@salukitec.com  
Address: No. 367 Fuxing N Road, Taipei 105, Taiwan (R.O.C.)

## Safety and Symbols

**Terms used in the manual.** Following terms may appear in the manual.



**Warning.** Warning statement indicates conditions and actions that will likely endanger life security.



**Caution.** Caution statement indicates conditions and actions that will likely cause product damage or other property damage.

**Terms in product.** Following terms may appear in the product:

**Danger** indicates if you conduct such operation, it will likely cause immediate harm to you.

**Warning** indicates if you conduct such operation, it will not likely cause immediate harm to you.

**Caution** indicates if you conduct such operation, it will likely cause product damage or other property damage.

**Symbols in product.** Following symbols may appear in the product:



High voltage

Cautions! Please refer to the manual.

Protective ground internal

Measuring ground internal

Shell ground internal

## General Security Overview

Please know about following safety precautionary measure to avoid any injure, and to prevent damaging the product and any product connecting with the product. In order to avoid possible dangers, please use the product as stipulated.

**Only qualified personnel can carry out maintenance operation.**

**Avoid fire and personal injury.**

**Use the right power line.** Only approved dedicated power line of the product in country where the product lies can be used.

**Make the product grounded.** The product is grounded via earthling conductor of power supply.

In order to avoid lightning stroke, the earthling conductor must be connected to the ground. Before connecting the product's input or output ends, please do ground the product correctly.

**Check the rated values of all terminals.** In order to avoid firing and striking by overlarge current, please check all the rated values and marks explanations of the product, and look up product manual before connecting the product so as to know about the details of rated values.

**Do not operate while keeping the cover open.** In case that the outer cover or panel is open, please do not operate the product.

**Use suitable fuse.** Only fuses with specified fuse types and specified index for the product can be used.

**Avoid circuit exposure.** After powering on power supply, please do not touch the exposed joints and elements.

**When you doubt there is any failure occurred in the product, please do not operate.** If you have doubt that the product has been out of order, please ask qualified maintenance personnel to check it.

**Please keep it ventilated properly.**

**Do not operate the product in damp environment.**

**Do not operate the product in inflammable and explosive environment.**

**Please keep the product surface clean and dry.**

# Contents

<b>Chapter 1 Overview .....</b>	<b>8</b>
<b>Chapter 2 Technical Parameters .....</b>	<b>9</b>
2.1 Conditions of Operating Environment .....	9
2.2 Instrument's Input Characteristics .....	9
2.3 Time Base .....	10
2.4 Other Characteristics .....	11
<b>Chapter 3 Panel Introduction .....</b>	<b>12</b>
3.1 Explanatory drawing of Front Panel Operation .....	12
3.2 Indicator Light in Front Panel .....	13
3.3 Schematic Diagram of Operation Interface of Front Panel User .....	14
3.4 Explanatory Drawing of Back Panel .....	15
<b>Chapter 4 User's Guide .....</b>	<b>17</b>
4.1 Works before Measuring .....	17
4.2 Menus Display .....	17
4.3 Value Input .....	17
4.4 Function Keys Use .....	19
4.5 Using Auxiliary Function Key .....	25
<b>Chapter 5 Remote Control Interface .....</b>	<b>27</b>
5.1 Hardware Connection of Programmable Interface .....	27
5.2 Error Messages .....	31
<b>Chapter 6 Programming Guide .....</b>	<b>33</b>
6.1 Programmable Command Introduction .....	33
6.2 Programmable Commands Syntax .....	36
6.3 Explanation of Programmable Command .....	40
<b>Chapter 7 Precautions and Maintenance .....</b>	<b>46</b>
7.1 Error Handling .....	46
7.2 Maintenance Precautions .....	46

## Chapter 1 Overview

The S4382 series microwave frequency counter is a newly developed high-precision frequency counter by our company. Its measurement control is realized by high-performance singlechip will control its functions, process data and display measurement. S4382 series frequency counter adopts reciprocal counting and digit interpolating technologies, realizing high-precision measurement all through the scaling range; what's more, it adopts CPLD programmable devices, which increase the counter's level of integration and reliability.

### Main Characteristics

- High measuring accuracy, its resolution in full frequency rage can reach as high as 1Hz, and it can also select high resolution of 9 digits per second to measure in low-frequency high resistance channel.
- Microwave channel has the function of automatic measurement and manual rapid measurement.
- It has the functions of scaling/offset, limits, relative, average calculating operation.
- The set mode of current instrument is automatic save so the information will not be lost in shut-down.
- It can save 9 complete instrument settings.
- RS232 general serial interface is standard configuration.
- IEEE488 general programmable interface, LAN interface and USB serial interface are selected.
- The instrument adopt color large screen LCD, so its display is rich, with attractive appearance and small volume, user-friendly.



## Chapter 2 Technical Parameters

### 2.1 Conditions of Operating Environment

The instrument is applicable for conditions stipulated in group II of GB6587.1-86-6587.8-86 “environment requirements for electronic measuring instrument”, that’s the operating ambient temperature is 0 to +40°C, relative humidity is 5 - 90%. It is suggested to preheat the instrument for more than half an hour for cold start, meanwhile, it shall make sure the instrument is well grounded so as to guarantee its measuring performance.

### 2.2 Instrument’s Input Characteristics

<b>Frequency range</b>	S4382A: 10Hz - 9GHz, S4382B: 10Hz - 12.4GHz, S4382C: 10Hz - 18GHz, S4382SD: 10Hz - 20GHz, S4382SE: 10Hz - 22GHz, S4382D: 10Hz - 26.5GHz, S4382E: 10Hz - 36GHz, S4382F: 10Hz - 40GHz
<b>Measurement error</b>	$\pm 5 \text{ LSD} \pm \text{trigger error} \pm \text{time base error} \times \text{measured signal frequency}$

#### Channel A:

<b>Frequency range</b>	10Hz - 80MHz
<b>Resolution</b>	1Hz, 10Hz, 100Hz, 1KHz, 10KHz, 9digits/sec high resolution is selectable
<b>Input sensitivity</b>	25mVrms (-19.1dBm) 10Hz-50MHz, 50mVrms (-13dBm) 50MHz-80 MHz
<b>Maximum input level</b>	1Vrms (+13dBm)
<b>Burn-out level</b>	3Vrms (+23 dBm)
<b>Input impedance</b>	1M $\Omega$
<b>Low pass filter</b>	The cut-off frequency is about 100kHz, selectable.
<b>Coupled mode</b>	AC

<b>Frequency range</b>	60MHz - 3.2GHz (the typical value of upper frequency limit can
------------------------	--

	reach 3.8GHz, however, there is no technique data provided)
<b>Resolution</b>	1Hz, 10Hz, 100Hz, 1KHz and 10KHz are selectable.
<b>Input sensitivity</b>	25mVrms (-20dBm) $\leq$ 3GHz, 40 mVrms (-15dBm) >3GHz
<b>Maximum input level</b>	1V rms (+13dBm)
<b>Burn-out level</b>	3Vrms (+23 dBm)
<b>Input impedance</b>	50 $\Omega$
<b>Coupled mode</b>	AC

*Channel A is applicable for input signals that amplitude modulation degree  $\leq$ 30%, and their enveloping valley value shall meet input sensitivity.*

#### Channel B:

<b>Frequency range</b>	2GHz - 40GHz (Note: 500MHz-2GHz can also be measurable, but there is no technique data provided. The frequency is recommended to be measured with channel A, and its burn-out capacity is stronger, and maintenance costs will be less)
<b>Resolution</b>	1Hz, 10Hz, 100Hz, 1KHz, 10KHz are selectable
<b>Input sensitivity</b>	$\leq$ -20dBm 2GHz-18GHz (-25dBm Typical value), $\leq$ -15dBm 18GHz-26.5GHz (-20dBm Typical value), $\leq$ -10dBm 26.5GHz-36GHz (-15dBm Typical value), $\leq$ -5dBm 36GHz-40GHz (-10dBm Typical value)
<b>Maximum input level</b>	+7dBm (that less than 3GHz are typical values)
<b>Burn-out level</b>	+20dBm
<b>Input impedance</b>	50 $\Omega$
<b>Standing-wave ratio</b>	< 3:1 (typical)

## 2.3 Time Base

Internal crystal oscillator (switch on the main switch in back panel, power light in front panel displays orange, then the internal constant temperature crystal oscillator begins preheating; if external time base is selected when switching the power switch in front panel, the instrument will automatically stop supplying power to internal constant temperature crystal oscillator).

<b>Internal crystal oscillator</b>	Nominal frequency	10MHz
	Daily aging rate	$1 \times 10^{-8}$ / day (Standard) $5 \times 10^{-9}$ /day (Option) $3 \times 10^{-9}$ / day (Option)
<b>External time base input</b>	Frequency	5MHz or 10MHz
	Amplitude	$\geq 1V_{p-p}$
<b>Internal time base input</b>	Frequency	10MHz sinusoidal wave
	Amplitude	$\geq 1V_{p-p}$

## 2.4 Other Characteristics

<b>Save and Recall Functions</b>	The instrument in measuring condition can realize automatic save so its data will not lose after shut-down. In addition, the instrument can also store as many as 9 measuring modes for recalling.															
<b>Remote Control Interface</b>	RS232 general serial interface, IEEE488 general interface (option), USB general serial interface (option) and LAN interface (option)															
<b>IEEE488 General Interface Function</b>	SH1 (complete source hook function), AH1 (complete recipient hook function), T4 (complete speak function besides only speak), L4 (complete listen function besides only listen), SR1 (complete service request function), RL1 (complete remote control/local function), DC1 (complete device clearance function).															
<b>RS232 General Serial Interface</b>	<p>The back panel RS232 gang socket is DB9 nine-needle needle socket. The pin is defined as below:</p> <table border="1" style="margin-left: auto; margin-right: auto;"> <thead> <tr> <th>Pin No.</th> <th>Symbol</th> <th></th> </tr> </thead> <tbody> <tr> <td>2</td> <td>RXD</td> <td>Receive data</td> </tr> <tr> <td>3</td> <td>TXD</td> <td>Send data</td> </tr> <tr> <td>5</td> <td>GND</td> <td>Signal ground</td> </tr> <tr> <td colspan="3" style="text-align: center;">Other pins: un-connected</td> </tr> </tbody> </table>	Pin No.	Symbol		2	RXD	Receive data	3	TXD	Send data	5	GND	Signal ground	Other pins: un-connected		
Pin No.	Symbol															
2	RXD	Receive data														
3	TXD	Send data														
5	GND	Signal ground														
Other pins: un-connected																
<b>Program Control Commands</b>	Adopts standard commands for programmable instruments															
<b>Power Supply</b>	Voltage: AC 100V-242V, Frequency: 47Hz-63Hz, Power dissipation: 40VA															
<b>Dimension</b>	270mm×370mm×110mm (W×D×H)															
<b>Weight</b>	About 2.5kg															

## Chapter 3 Panel Introduction

### 3.1 Explanatory drawing of Front Panel Operation

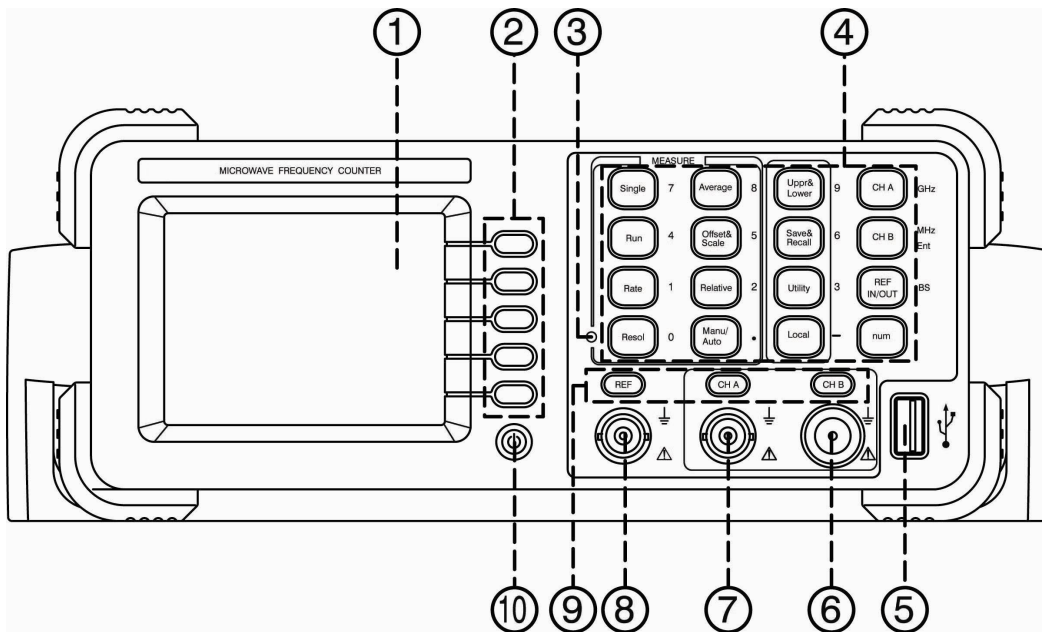

- |                          |                              |  |
|--------------------------|------------------------------|--|
| 1 LCD display screen     | 5 USB Host                   | 9 Indicator light of time base and channel |
| 2 Menus operating key    | 6 Channel B output           | 10 Power switch                            |
| 3 Gate light             | 7 Channel A output           |  |
| 4 Function selection key | 8 Time base input and output |  |

**Definition in the manual:** the text indication for keys in the manual is the same as that of in panel. What remarkable is that the function keys in operating panel are indicated with characters surrounded by a bracket, for example, [run] indicates the function key marked with character “run” in front panel, among which, menu operating keys are defined as [F1] to [F5] front top to bottom.

### 3.2 Indicator Light in Front Panel

There are totally 5 groups of different LED indicator lights, which are described as below:

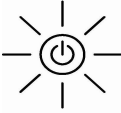
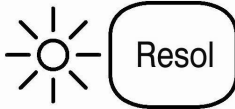
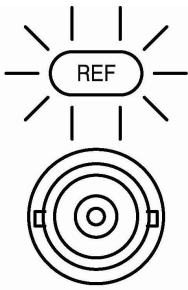
Indicator lights	Meanings
	<p>Power light. After plugging in power line, if the main power switch in back panel has been in open status, then power button in front panel will display orange. The constant temperature crystal oscillator in instrument begins preheating. Press the power button then it displays green, and the instrument finishes initialization and enters into measuring condition.</p>
	<p>Gate light</p>
	<p>External time base input light. When the light is on, it means now there are external time base signal input and the time base set is external; when the light is out, it means now there are internal time base signal output or time base set is external but there is no external signal input. Note: Four using external time base, it shall firstly select the key as external time base input; meanwhile connect the external time base into BNC socket.</p>

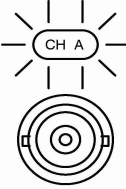
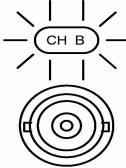
	<p>Channel A set light. When the light is on, it means the current channel set is channel A, and pressing the key can select high impedance input or low impedance input.</p>
	<p>Channel B set light. When the light is on, it means the current channel set is channel B, and it is low impedance input.</p>

### 3.3 Schematic Diagram of Operation Interface of Front Panel User

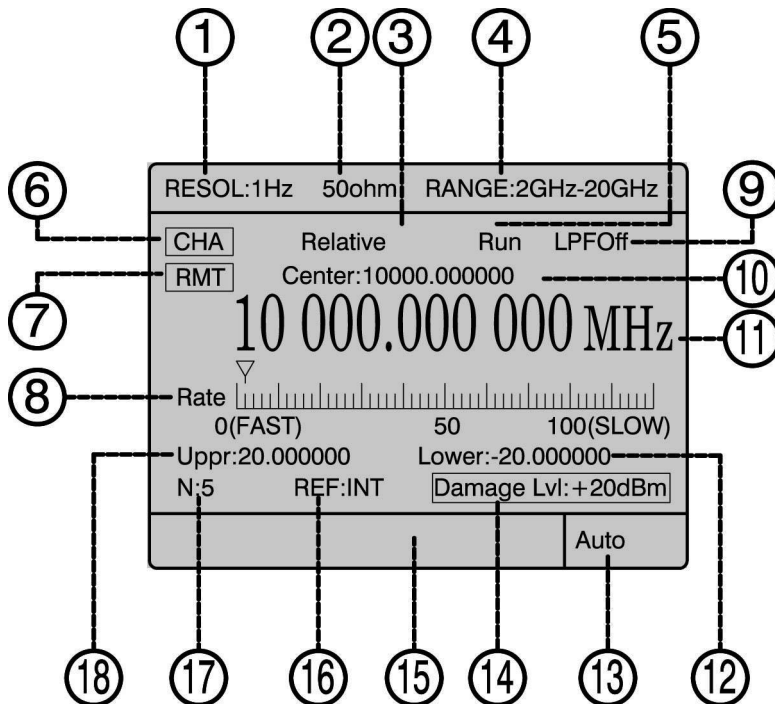

- 1 Display area of resolution;
- 2 Display area of current channel input impedance;
- 3 Display area of current measuring functions or operate mode;

- 4 Display area of current channel's frequency range;
- 5 Display area of current measuring mode;
- 6 Display area of current channel;
- 7 Display area of remote control sign;
- 8 Display area of current rate scale;
- 9 Display area of current low-pass status (display only in channel 1);
- 10 Display area of centre frequency of current measuring functions or operate mode;
- 11 Display area of current measuring result;
- 12 Display area of lower frequency or scale value;
- 13 Display area of current measuring function;
- 14 Display area of burn-out voltage;
- 15 Display area of error message;
- 16 Display area of time base signal input mode;
- 17 Display area of average time;
- 18 Display area of upper limiting frequency or offset value;

### 3.4 Explanatory Drawing of Back Panel

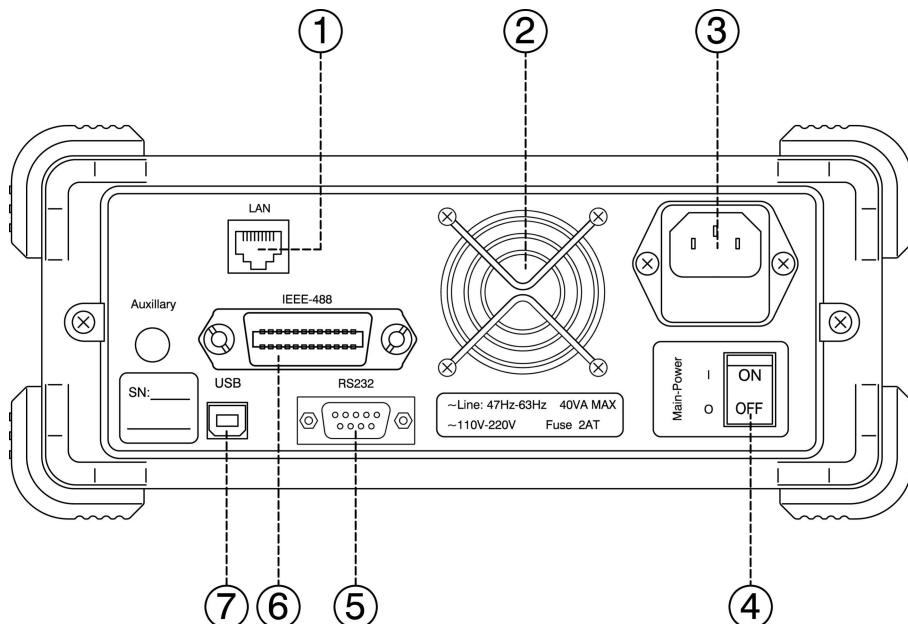

- 1 LAN interface (Option)
- 2 Electric fan
- 3 Power socket
- 4 Main power switch (After switched on, the internal constant temperature crystal oscillator in the instrument begins preheating, and the instrument is in standby mode).
- 5 RS232 general serial interface
- 6 IEEE488 general interface (Option)
- 7 USB general serial interface (Option)



## Chapter 4 User's Guide

### 4.1 Works before Measuring

#### 4.1.1 Preparations before Measuring

Firstly, check whether the supply voltage meets the working scope of voltage of the instrument carefully, after confirming without any error, plug the power line into the power socket in back panel of the instrument. Check the power supply conditions of test system carefully and make sure systems are grounded well, and the instrument shell and all exposed metals have been grounded. In case of connecting with other instruments, there shall be no potential difference among them.

#### 4.1.2 Instrument Starting Up

Connect the power line and switch on the main switch in back panel, the internal crystal oscillator the instrument has been powered on to preheat. The panel power button displays orange. Press the front panel power switch, then the power button displays green, and the instrument enters into initialization mode. Initialization interface of start up is displayed. After the initialization finishes, the instrument will enter into measuring mode automatically and the channel is channel 1.

### 4.2 Menus Display

The menu of the instrument is dynamically displayed. When there is no display in menu and press function keys with menu, the menu will pop up in the right side of the interface; press the menu key, if there is menu display before recently and the menu key has corresponding functions, thus it will display the recently displayed menu, otherwise there will be no response. After displaying the menu, it will delay for a time and disappear automatically.

When there is menu display or floating window display, but doesn't enter into digit input mode, press other function keys with menu option, then close the current menu and floating windows directly and display new menu; if press other menu keys, then corresponding floating windows will pop up.

### 4.3 Value Input

#### 4.3.1 Entering into value input mode

Under the condition of opening floating window, press [Number] key, then yellow NUM sign on red ground will appear at the right end of floating window's title bar, which means it can input number.

Press [Number] key in number input mode, then NUM sign will disappear, which means log out of number input mode. In the mode that floating window has been open but there is no number input, pressing other menu keys or function keys beyond the current functions can shift to corresponding functions directly.

#### 4.3.2 Input Number

1. In the mode of number input, all function keys corresponding to each green number in panel will shift to function of inputting corresponding numbers:

[Single] input number 7 [Average set] input number 8 [Limits judgment] input number 9  
[Run] input number 4 [Frequency offset operating] input number 5 [Save and recall] input number 6

[Rate] input number 1 [Relative measurement] input number 2 [System] input number 3  
[Resolution] input number 0 [Manual and automatic] input decimal point [Local] decimal point minus – For [Local], press once to input minus '-' and twice to cancel minus;  
[Channel A] Input unit GHz; [Channel B] input unit MHz when inputting frequency value and presume OK key when inputting non-frequency value; [Time base internal/external] input backspace key, that's to delete a number.

2. Pay attention to following circumstances when inputting values:

- ① The center frequency value can't be negative;
- ② For limit judgment, the negative is prohibited from inputting in upper limiting frequency and lower limiting frequency.
- ③ All values must be input within required scope;
- ④ Decimals are forbidden occurring in average time, scale value, GPIB address and rate value input;
- ⑤ Decimal point is forbidden occurring in the first value;
- ⑥ in case the first value is zero, it is forbidden inputting other numbers behind it besides decimal point.

## 4.4 Function Keys Use

### 4.4.1 Single Measurement Key

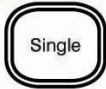

- Allow the frequency counter enter into single measurement function mode (if the frequency counter is in continuous measurement function mode) and conduct measurement for one time.
- Allow the frequency counter enter into single measurement function mode (if the frequency counter is in continuous measurement function mode and the average operating function has been activated) and conduct measurement for N times.

### 4.4.2 Continuous Measurement Key

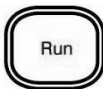

- Make the frequency counter conduct continuous measurement.
- Stop or cancel current measurement (if the frequency counter has been in continuous or single measurement modes already and it is conducting a measurement), begin a new measurement again.

### 4.4.3 Rate Set Key

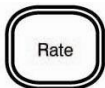

It can set rate value in popup menu, that's the speed of measuring speed in continuous measurement mode (besides changes of measuring speed caused by the high and low conditions of set resolution). The menu options are as below:

- Fast (FAST) the measuring speed is faster, which is about 0.1s/time.
- Middle (MIDDLE) the measuring speed is slow, which is about 5s/time;
- Slow (SLOW) the measuring speed is rather slow, which is about 8s/time;
- Setup (SETUP) The speed can be set at will, set value is 1-100, the larger the value, the slower it is. The triangle signs in scale display the current set rate value.

#### 4.4.4 Resolution Set Key



It can set resolution in pop-up menu:

[F1] - [F5] are 1Hz, 10Hz, 100Hz, 1kHz, 10kHz respectively.

#### 4.4.5 Set Key of Average Time



It can set the average time in pop-up menu and the menu options are as below:

- Average time (N) set the average operating time, and the values are integer in 1-100.
- Switch (STATE) set whether conduct average operation. If set it in on (ON), then the measuring results per time will be obtained after conducting average operations for N times; if set is in off (OFF), then it will not conduct average operation per time.

#### 4.4.6 Function Key of Frequency Offset



Conduct frequency offset operation on values measured manually or automatically, and the formula is as below:

Display result = (Measuring result × scal value) + offset value

Various parameters can be set in pop-up menu and specific options are as below:

- Offset (OFFS) set offset value;
- Scal (SCAL) Set scal value and its number range are all integers in 1-100.

#### 4.4.7 Function Key of Relative Measurement

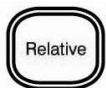

Conduct relative operation on values measured manually or automatically and what displays is frequency value obtained by making measured value minus center frequency. Compare the frequency value with the set upper and lower limiting frequencies, then the

calculated values beyond upper and lower limits are out of scope values. Once there are values out of scope, it will display “ERROR” and so does warning information. Its menu options are as blow:

- Center frequency (CENT) Set center frequency;
- Upper (UPPER) Set the upper limit value of the difference after comparing measured results with center frequency;
- Lower (LOWER) Set the lower limit value of the difference after comparing measured results with center frequency;

#### 4.4.8 Function Key of Switching Manual Measurement and Automatic Measurement



If the current measurement mode is manual, then press the key to switch to automatic measurement mode; if the current measurement mode is automatic and in channel B, then press the key to switch to manual measurement mode. It can't conduct manual measurement in channel A. When switching to manual measurement mode, options in pop-up menu are as below:

- Center frequency (CENT) Set center frequency, and its range is from 2GHz to maximum allowable measured frequency values.

Compared the manual measurement and automatic measurement, it finds manual measurement can measure the frequency of measured signals faster, while the premise of using the measurement function is that the user has to know about the measured frequency range clearly, which shall not be  $\pm 20\text{MHz}$  larger than the manually set center frequency, otherwise, it will obtain error measured results. If user wants to measure the signals below 3GHz (typical value reaches 3.8GHz) rapidly, it is suggested to use channel A. In addition, it doesn't need to set center frequency, and only the correct channel input is OK.

Once ultra limit occurs, “ERROR” will be displayed and so does warning message But if user fails to know about the frequency range of measured signals, warning message will not be likely displayed, but there is the error measured results.

#### 4.4.9 Function Key of Limits Judgment



The function key is to judge the limits of current measured results, that's to say, if the measured results exceed specified upper or lower frequency, it will stop measuring and display "ERROR" and warning message or go on measuring. Options in its pop-up menu are as below:

- On fail (ON FAIL)            Make the setting that allow it go on (GO ON) or stop (STOP) measuring in case that measured results exceed limits. When set in on go on, the function display area in window will display "limit judgment off". When set in on stop, the function display area in window will display "limits judgment disconnect".
- Upper (UPPER)            Set upper limiting frequency.
- Lower (LOWER)            Set lower limiting frequency.

#### 4.4.10 Function Key of save and recall



Working modes which can save the current working mode (including function, channel and time base selection) or recall stored working modes. Options in its pop-up menu are as below:

- Recall (RECALL)            Recall the previous stored modes and its range is group 1-9;
- Save (SAVE)                Save the current set modes and its range is group 1-9.

#### 4.4.11 System Set Key

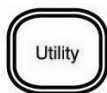

Set the mode of current instrument and options in its pop-up menu are as below:

- Interface set (INTERFACE)    Select the types of general serial interfaces: USB interface or RS232 general serial interfaces;
- Baud rate (BAUD)            Set the baud rate of general serial interfaces and there are 5 sets: 2400, 4800, 9600, 19200 or 38400;
- Parity (PARITY)             Set the parity of general serial interfaces and there are 3 sets: EVEN, ODD, NONE;
- GPIB addresses (GPIB ADDR)    Set the address of GPIB interface, and its number range

are integers in 1-30;

- Language (LANGUAGE) set the use language, Chinese and English.

#### 4.4.12 Function Key of Returning to the Local

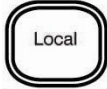

In the mode of remote control, it can return to local operation by pressing the key.

#### 4.4.13 Function Key of Channel A set/high resolution measurement



It can set the measurement range of channel A or the measurement of switch's high resolution. In the mode of manual measurement, it must log out the manual measurement mode, can it allows to switch to channel A. Options in its menu are as below:

- Filter set (FILTER) Set the mode of filter, which is valid to 10Hz-80MHz frequency measurement range. Under the condition of channel 1, the current low-pass set mode will be displayed in display area of filter mode. And it can't set when it is in channel B;
- Frequency range (RANGE) Set the range of measuring frequency: 10Hz-80MHz or 60MHz-3.2GHz. If the 10Hz-80MHz is set, that's the channel 1, it will display the current low-pass set mode in display area of low-pass mode.
- High resolution measurement (H RESOL), If select the high resolution measurement mode, then the frequency measurement range can only within 10Hz-80MHz, shut down the high resolution measurement and the instrument switches to automatic measurement mode. In the mode of high resolution measurement, functions of frequency offset, relative operation, manual measurement, automatic measure and limits judgment will fail.

#### 4.4.14 Function Key of Channel B Set



Set the current channel in channel B. In the mode of high resolution measurement, it has to shut down the high resolution measurement mode, can the channel A is switched to channel B.

#### 4.4.15 Function Key of Time Base Set



Set the time base signals as internal output or external input. When it displays internal (INT), it means time base signal output, and time base signal input for external (EXT) displayed.

#### 4.4.16 Number Input Marking Key



When the floating window opens, and it doesn't enter into number input mode, after pressing the key, the "NUM" mark will be displayed in the right end of title bar of the floating window, which means it enters into number input mode; in the number input mode, if press the key, the "NUM" mark in floating window will disappear, which means number input mode log out.

#### 4.4.17 Interface for Setting LAN Interface Parameters

Through the LAN Settings menu, you can set the LAN communication mode, local IP address, gateway address (HOST IP address), subnet mask, local port, and host port. Default values are as follows:

Local IP address	169.254.21.209
IP address of the host	169.254. 213. 102
Subnet mask (fixed)	255.255.0.0
Local port number	8080
Port number of the upper computer	2020
Communication methods	UDP

**Press the [REF IN/OUT] key to delete a character and press the [CH B] key to confirm the current input value. Finally, only press the "OK" menu IN the LAN**



**Settings menu to confirm all the input parameters. Otherwise, the input will be cancelled and the previous parameters will be restored. When entering data, press the corresponding menu key or other menu keys to cancel the input. If you press THE IP address menu item to enter the IP address state, press the IP Address menu item to cancel the input and display the value before the input.**

- 1 Set the communication mode of the LAN interface

You can press the Communication Mode TAB to set the communication mode to UDP or TCPIP.

- 2 Set the local IP address of the LAN interface

Press THE IP address menu key and enter four groups of digits separated by decimal points. The maximum value of each number is 255.

- 3 Set the gateway address of the LAN interface (IP address of the host)

Press the "More Settings" menu key to go to page 2, then press the "Gateway Settings" menu key, and enter four groups of numbers separated by decimal points. The maximum value of each number is 255.

- 4 Set the subnet mask of the LAN interface

Press More Settings to go to page 2, then press Subnet Mask, and enter four groups of numbers separated by decimal points. The maximum value of each number is 255.

- 5 Set the local port of the LAN interface

Press the "More Settings" menu key to go to page 2, then press the "Local Port" menu key, and enter a maximum value of 65535.

- 6 Set the host port of the LAN port

Press the More Menu key to go to page 2. Then press the Host Port menu key and enter a maximum value of 65535.

## 4.5 Using Auxiliary Function Key

The display lamps in input and output socket of time base signals; sockets of channel A and channel B are auxiliary function keys.

### 4.5.1 Auxiliary Function Key of Time Base Input and Output



Set the time base signal as internal output or external input. When it displays internal (INT), it means time base signal output, and time base signal input for external (EXT) displayed.

#### 4.5.2 Auxiliary Function Key of Channel A



Switch to channel A in mode of channel B and the frequency range is the recently set frequency range; As in mode of channel A, switch the frequency range directly. While in the mode of manual measurement, it has to log out the manual measurement, can it allow switching to channel A from channel A.

#### 4.5.3 Auxiliary Function Key of Channel B

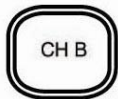

Switch to channel B while in channel A. In the mode of high resolution measurement, it has to shut down the high resolution measurement mode, can the Chanel B is switched to channel A.

## Chapter 5 Remote Control Interface

S4382 microwave frequency counter has three interfaces: USB general serial interface, RS232 general serial interface and IEEE488 general programmable interface. Among them, RS232 general serial interface is standard configuration, which USB general serial interface and IEEE488 general programmable interface are options. S4382 microwave frequency counter adopts programmable commands which are compatible with Standard Commands for Programmable Instruments. And all programmable commands adopt ASCII character to represent. So does the data returning to computer from signal source. The programmable commands of RS232 general serial interface are the same as that of IEEE488 general programmable interface. It can realize remote control over keys in all panels via programmable interface (USB general serial interface, RS232 general serial interface or IEEE488 general programmable interface) by sending standard commands for programmable instruments.

### 5.1 Hardware Connection of Programmable Interface

Before conducting programmable operations, firstly connect the programmable interface of signal source with computer together, and set the parameters of programmable interface well.

#### 5.1.1 RS232 General Serial Interface

##### 1) Connection of RS232 General Serial Interface

RS232 general serial interface in back panel of signal source is standard nine-needle socket, so it can connect the computer with signal source together with standard RS232 connecting cables. Refer to following figure for connecting type of the cables.

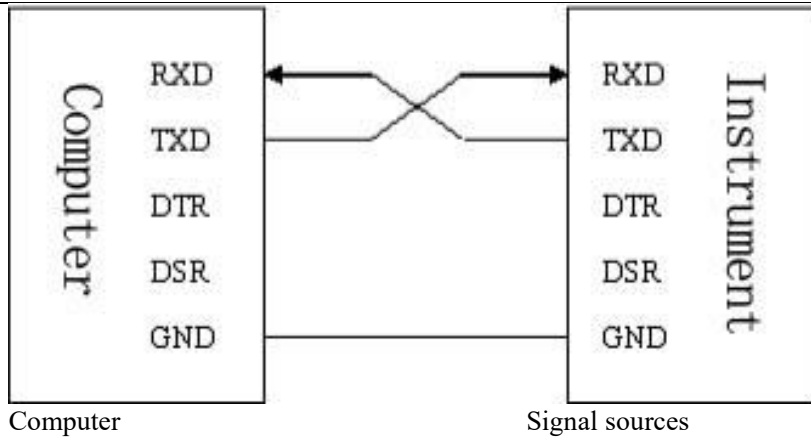

**Note:** RS232 interface is non-hot plug and pull interface, therefore it must disconnect the power supply of the signal when plugging or pulling RS232 interface cable.

## 2) Parameters Setting of RS232 General Serial Interface

The interface parameters (baud rate, parity bit) setting of RS232 general serial interface is realized via system setup menu. Refer to 3.4.11 for specific settings.

### 5.1.2 GPIB General Programmable Interface

- 1) The connecting type of GPIB general programmable interface is very simple, that's to use GPIB cable to connect the signal sources with GPIB communication equipment tighter.



**Note:** GPIB interface is non-hot plug and pull interface, therefore it must disconnect the power supply of the signal when plugging or pulling GPIB interface cable.

## 2) Address Setting of GPIB General Programmable Interface

The address setting of GPIB interface is realized via system setup menu. Please refer to 3.4.11 for specific settings.

### 5.1.3 USB General Serial Interface

- 1) Connection of USB General Serial Interface

The connection of USB general serial interface is very simple, that's to use USB connecting cables provided in appendix to connect the signal sources with the USB

interface in computer together.

2) Parameters Setting of USB General Serial Interface

The parameter setting of USB general serial interface is the same as that of RS232 interface. Please refer to 3.4.11 for specific settings.

3) Installation USB Device Driver

The USB device driver is saved in mating CD supplied in instrument appendixes.

5.1.4 LAN interface

1) Connection of LAN interfaces

The instrument and another device cannot be directly connected by one network cable, but must be connected by two network cables through a HUB.

2) Set the parameters of the LAN interface

For details about HOW to set LAN interface parameters, see 3.4.17.

5.1.5 Returning to local mode from remote control mode

The frequency counter is in panel key control (local) mode at startup. Once it enters in remote control mode, the instrument will make no response to other keys in front panel besides [Local] function key. For in remote control mode, press [Local] function key then the instrument can enter into local mode manually.

5.1.6 Communication Test Program of RS232, USB General Serial Interfaces

1) Installing Test Program

The communication test program is saved in mating CD supplied in instrument appendixes.

2) Make use of communication test program to test RS232 and USB general serial interfaces.

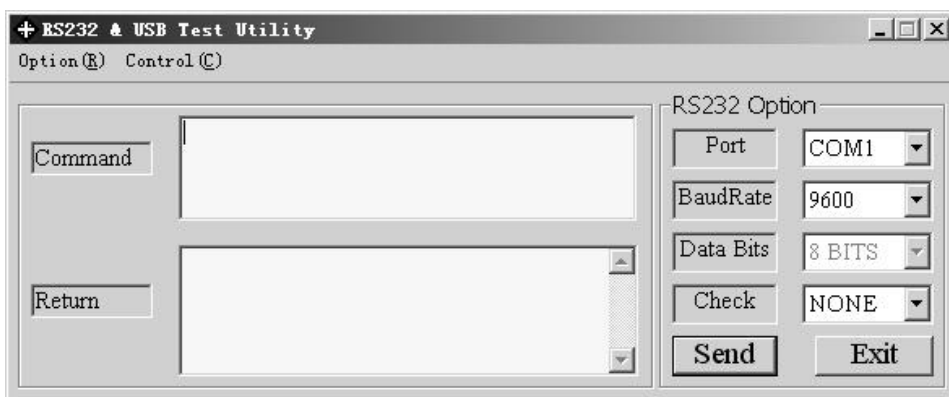

Command input window;

Return message window;

RS232 Option: Seinterface parameters;

Port: Select the port connecting computer to instrument;

Baud Rate;

Data Bits & Check;

Send:

Exit:

### 5.1.7 LAN interface test program

#### 1) Install the test program

Run the netassist. exe file in The Network Test Assistant directory in THE CD-ROM Z. No installation is required.

#### 2) Test the LAN interface with network Test Assistant

UDP communication protocol test interface is as follows:U

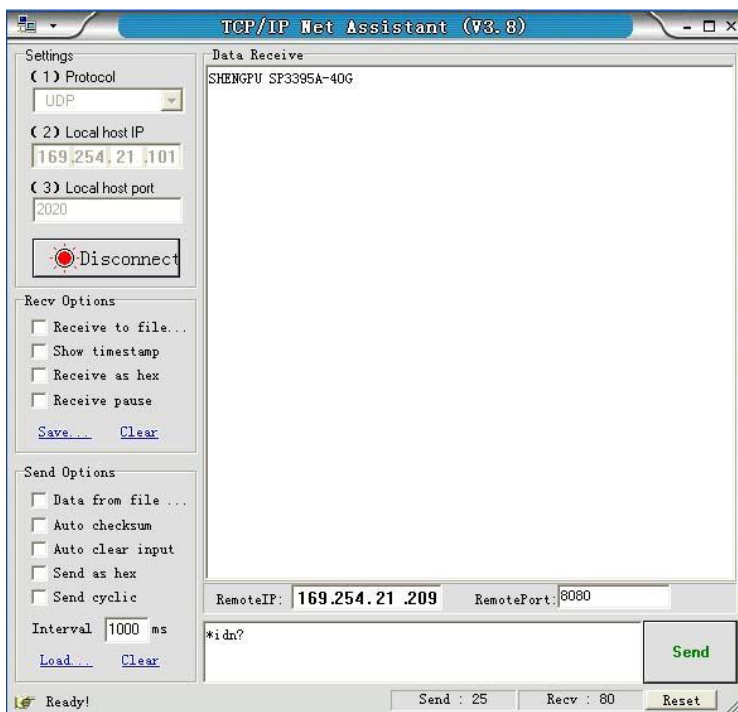

TCPIP communication protocol test interface is as follows:

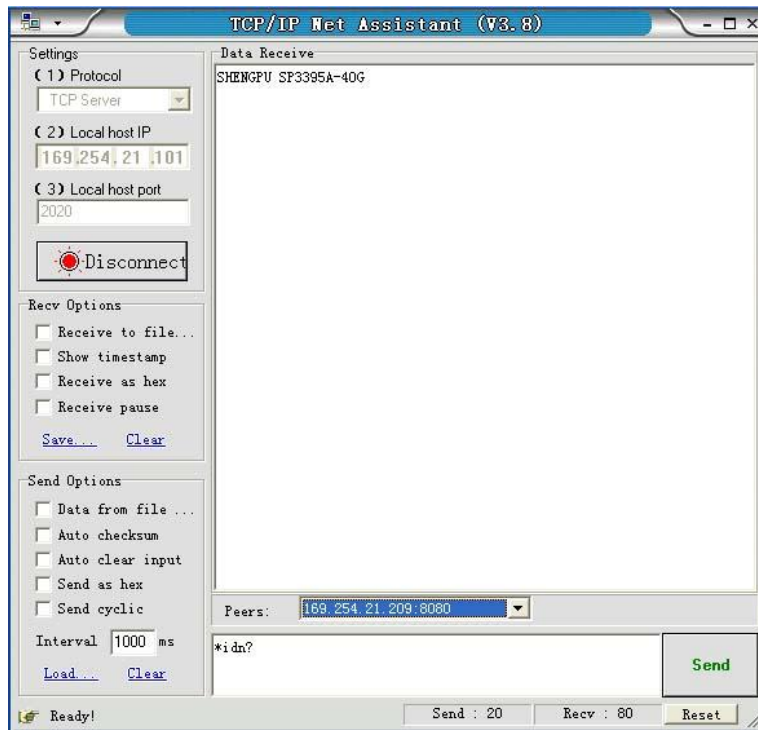

**Note:** the interface parameters must be identical to that of instrument settings, otherwise communication fails.

## 5.2 Error Messages

Displays	Meanings
<i>ERRORN00</i>	Data in first place shall not be zero.
<i>ERRORN01</i>	Negative input is forbidden.
<i>ERRORN02</i>	The upper limiting value is smaller than the lower limiting value.
<i>ERRORN03</i>	Floating point input is forbidden.
<i>ERRORN04</i>	The parameter value is out of range.
<i>ERRORN05</i>	Input of number following zero or direct decimal point input is forbidden.
<i>ERRORN06</i>	Unit GHz input is forbidden.
<i>ERRORN07</i>	There is no valid data input.
<i>ERRORN08</i>	There is no data saved in the area.

<i>ERRORNo09</i>	The measured results are out of range.
<i>ERRORNo11</i>	The channel A can't conduct manual measurement.
<i>ERRORNo12</i>	The instrument fails to operate in high resolution mode.
<i>ERRORNo13</i>	The frequency value is less than zero.
<i>ERRORNo14</i>	It exceeds the maximum allowable set frequency value.
<i>ERRORNo15</i>	The center frequency setting in manual measurement mode is less than minimum allowable frequency value.
<i>ERRORNo16</i>	There is no register to save data.
<i>ERRORNo17</i>	There is no interface.
<i>COMMANDERROR</i>	The form of remote control command goes wrong.
<i>OVER FLOW</i>	The measured results are out of range.



## Chapter 6 Programming Guide

### 6.1 Programmable Command Introduction

The programmable commands of frequency counter can be compatible with standard commands of programmable instruments, and also the representation modes of programmable commands are identical to SCPI language.

#### 6.1.1 Meanings of partial SCPI Commands Symbols

- [ ] Characters in the bracket are selectable. For example: CALCulate[1], can be written either in CALCulate or CALCulate1. Please know about that the bracket is not a command symbol.
- AUTO|MANUal Indicate choose either, either AUTO or MANUal.
- <Boolean> Indicate switch parameters, 0 or 1. Meanwhile, it can also indicate OFF or ON. OFF is 0 and ON is 1. The returning of frequency counter is only the 0 or 1.
- <Numeric\_Value> Indicates a numerical value, and refer to commands reference for specific numerical value.
- SENSE Indicate the commands can be the part with capitals only, also be complete character. For example, SENSE command symbol indicates the following representations are all right, SENSE or SENS.

6.1.2 The frequency counter makes response to following 4 IEEE488.2 general commands. All these general commands begins with “\*” and generally have nothing to do with measurement settings.

Introduction to IEEE488.2 General Commands

Mnemonic symbol	Names	Functions
*IDN?	Instrument identify and query instruction	Query instrument marks.
*RCL <Numeric_Value>	Recall instruction	Recall saved parameter settings and modes.

*RST	Reset instruction	Reset the instrument to startup mode.
*SAV <Numeric_Value>	Save instruction	Save the instrument’s current parameter settings and modes.

6.1.3 Frequency Counter SCPI Commands

SCPI commands include all measurement functions and settings, and adopt tree-based layering command structure mode. And use “:” to connect the subsidiary key words with superior layer key words together. For example, the CALC:TYPE? is connected with CALC 与 TYPE? by using “:”, which indicates TYPE? is CALC’s inferior layer key word.

Generally, SCPI commands always include query command; it can obtain a command’s query command by adding “?” after it. For example, CALC2:AVER:STAT 0 is shut down average operation function, while CALC2:AVER:STAT? is command of querying the startup condition of average operation function. But there is no query command for partial setting commands, while partial commands only have enquiry commands. See following table for frequency counter SCPI commands.

Introduction to S4382 SCPI Command

Key words/ Syntax	Parametric form	Notes
:ABORt		No query command. The terminal is conducting measurement.
:CALCulate[1] :TYPE :OFFSet :FREQuency0 [:DATA] :SCAL :RELAtive :FREQuency0 [:DATA] :LOWer [:DATA] UPPer [:DATA] :LIMit :LOWer [:DATA] UPPer [:DATA]	MEASure OFFSet RELAtive LIMit    <Numeric_Value>[Hz] <Numeric_Value>  <Numeric_Value>[Hz]  <Numeric_Value>[Hz]  <Numeric_Value>[Hz]  <Numeric_Value>[Hz]  <Numeric_Value>[Hz]	Set arithmetical operation and limits judgement function.  Set scal/offset to operate offset frequency. Set scal/offset to operate scal value.  Set relative operation and center frequency.  Set relative operation and lower limiting frequency.  Set relative operation and upper limiting frequency.  Set limits judgment and lower limiting

		frequency.  Set limits judgment and upper limiting frequency.
:CALCulate2 :AVERage :COUNT [:STATe]	<Numeric_Value> <Boolean>	Set the sampling time of average operation function. Activate/close average operation function.
:MEASure :TYPE :MANUal :FREQUency0 :REFerence	AUTO MANUal HIRESol  <Numeric_Value>[Hz] INT EXT	Set measurement function. Set manual center frequency measurement. Set internal or external time base.
:INITiate :AUTO  :CONTInuous  [:IMMediate]	<Boolean>   <Boolean>	In case that the limits judgment is set in ON, then the measurement will stop automatically when measured results exceeds the upper limit; when it is in OFF, the close will stop automatically. Set continuous measurement mode or single measurement mode. No query command. Make the instrument conduct a measurement immediately.
:INPut :FILTer [:LPASs] [:STATe]	<Boolean>	Open/close channel A low-pass filter.
:MEASure?		Only query command. Conduct a measurement and return measured results.
:READ?		Only query command. Return measured results.
[:SENSe] :FUNctIon [:ON]  :FREQUency :ARM	<Sensor_Function>(as follows) “[:][XNONE:]FREQUency [1]” “[:][XNONE:]FREQUency 2” “[:][XNONE:]FREQUency 3” “[:][XNONE:]FREQUency :CHECK”  1Hz 10Hz 100Hz 1kHz 10kHz	Set measurement function. Channel A1 frequency measurement. Channel A2 frequency measurement. Channel B frequency measurement. Frequency self-check measurement.  Set the resolution of frequency measurement.

:SYSTem		
:COMMunicate		
:GPIB		Set GPIB (IEEE488) address.
[:SELF]		
:ADDRess	<Numeric_Value>	
:SERial		
:TRANsmit		Set RS232 baud rate.
:BAUD	2400 4800 9600 19200 38400	
:PARity		Set RS232 parity bit.
[:TYPE]	EVEN ODD NONE	
:KEY	<Numeric_Value>	No query command, which is equal to press one key.
:LOCal		No query command. Only valid for RS232 general serial interface. Make the instrument return to local mode.
:MEASure		
:PAUSE	<Numeric_Value>[s]	Set measurement pause time.

The significant condition of SCPI command in frequency counter is identical to that of panel keys in frequency counter. For example, after setting the measurement function in channel B as manual measurement, then set the channel as channel A, as manual measurement can't be operate in channel A, therefore, the commands fails, and return error message, meanwhile there will be no change in the instrument's interface set.

## 6.2 Programmable Commands Syntax

### 6.2.1 Programmable Commands Overview

S4382 programmable commands are command symbols sent by controller (like computer) to frequency counter, which can be sent both via RS232 general serial interface, AND, USB IEEE488 general programmable interface. The command synboles are ASCII characters and so are the returned message composed of ASCII characters. In case of using IEEE488 general programmable interface, frequency counter will send end symbol as well as EOI signal.

S4382 programmable commands conform to SCPI language specifications.

### 6.2.2 Types and Forms of Programmable Commands

Programmable commands can be divided into two types: IEEE488 general commands and SCPI commands. Generally, IEEE488 general commands are used to

conduct reset to known mode, save and recall mode etc, which has nothing to do with measurement.

#### 6.2.2.1 General Command Forms

The general command begins with asterisk (\*) and will probably contain parameters. Take following general commands for example:

```
*RST    *IDN?    *RCL 1
```

#### 6.2.2.2 SCPI Commands and Query Form

Functions realized by SCPI commands are generally settings on instrument. The command key words are divided into several layers, words following root command key words are subcommand key words, and what following key words are command parameters. The root command key words are connected with colon (:) to subcommand key words, and key words are connected to parameters with blank space. Take following command and its query command for example:

```
:MEAS:TYPE MANU  
:MEAS:TYPE?
```

MEAS is root key words; TYPE is secondary command key words, while MANU is command parameter.

### 6.2.3 S Basic Syntax Principles of SCPI Commands

#### 6.2.3.1 SCPI Layering Command Syntax

SCPI command form is tree-based layering structure, which can be divided into many subsystems, and a subsystem is composed of a root command and one or several layering subcommands. And the key words of latest layering subcommand are connected to command parameters with blank space. For query command, add a question mark (?) behind the key words of latest layering subcommand then use blank space to connect it with parameter (if there are parameters). If there are more than two parameters, they are connected with comma (,).

#### 6.2.3.2 General Commands Syntax

General command begins with asterisk (\*) then follow the general commands, which is connected with command parameter via blank space. For query command, add

question mark (?) after general command directly.

#### 6.2.3.3 Abbreviated Command

It can mix the capital and small letter tighter to represent SCPI command. The capitals in command description indicate the abbreviated form of such command. To enhance the readability of program, it can use complete command. Frequency counter can receive both abbreviated command and complete command.

For example, Command CALCulate, then both CALC and CALCULATE are receivable command, while other command forms, such as CALCU, CALCULA etc will result in error message. As both capitals and small letters can be used, therefore, CALCULATE, calculate or CALcuLaTe etc are receivable.

#### 6.2.3.4 Connection of Key Words in Commands

Root commands are connected with its subcommand via (colon). For an instance:

```
:MEAS:TYPE?
```

Among which, the first colon (colon at the beginning) can be omitted. That's to say, the command can be represented as:

```
MEAS:TYPE?
```

#### 6.2.3.5 Omissible Key Words

Omissible key words refer to key words surrounded by square bracket ([ ]). Note that the bracket is not a part of the key word, which can't be sent to frequency counter.

If key words in the bracket are omitted, frequency counter will automatically presume the omitted parts already existed, thus the omitting effect is the same as that of keeping them.

Take [:SENSe] subsystem command for an example:

```
[:SENSe]
```

```
:FREQuency
```

```
:ARM 1Hz
```

The root command key word is a omissible key word, thus the following two commands are receivable and their functions are identical to the originals.

```
:SENS:FREQ:ARM 1Hz
```

:FREQ:ARM 1Hz

### 6.2.3.6 Parameter Types

Parameters can be character, while so is number, but regardless the character or number, they are all represented with ASCII characters. The settings of all frequency values must be integer.

Followings are table fore parameter types:

Parameter types	Interpretation
<Numeric_Value>	Number. See corresponding commands details for specific number forms.
<Boolean>	A binary number, indicating true or false: 1 (ON) or 0 (OFF). Send ON or OFF only when querying.

### 6.2.3.7 Query Parameters

Generally, it can add question mark after command with parameters to query the current parameters mode. For example:

INPut:FiLTeR?

Query result returns to current channel A's low-pass filter mode, ON or OFF.

### 6.2.3.8 Parameter Unit

Generally, frequency parameters contain unit Hz, which can be omitted, regardless capital or small letter.

It may contain a prefix before the parameter unit, indicating multiple of the unit.

Symbol	Meanings
G	$10^9$
M	$10^6$
k	$10^3$

The unit prefix can either be capital or small letter. Please not both m and M

indicate M.

#### 6.2.3.9 Command End Mark

Programmable command takes line break (ASCII character 10 and hexadecimal 0AH) as end mark. So does the returned message from frequency counter. In case of using IEEE488 general programmable interface, send line break as well as EOI message.

#### 6.2.4 Compound Command

SCPI language is able to send two or more than two commands together, and use semicolon (;) to connect these commands and sent end mark at the end of several commands. For example:

```
*RST;:FUNC "FREQ 1"
```

The compound command has same function of that to send a :FUNC "FREQ 1" command again after sending the \*RST command.

The compound command can't exceed 10 instructions, otherwise commands will go wrong or partial commands will be lost.

### 6.3 Explanation of Programmable Command

#### 6.3.1 :ABORt Subcommand

```
:ABORt
```

This command has only executive command but no query command. After receiving this command, the frequency counter will exit the on-going measurement and enter idle state.

#### 6.3.2 :CALCulate[1] Subcommand System

##### 6.3.2.1 :CALCulate[1] :TYPE MEASure|OFFSet|RELAtive|LIMit

Set mathematical operation type: frequency offset operation (OFFSet), relative operation (RELAtive) or limit judgment (LIMit). Setting MEASure will close mathematical operation and switch to the last used measurement mode (automatic or manual measurement). Under high-resolution measurement mode, there is no mathematical operation function.

##### 6.3.2.2 :CALCulate[1] :OFFSet:FREQUency0[:DATA] <Numeric\_Value>[Hz]



Set the offset value of scaling/offset operation.

6.3.2.3 :CALCulate[1] :OFFSet:SCAL <Numeric\_Value>

Set the offset value of scaling/offset operation. The range of value is interger in 1-100.

6.3.2.4 :CALCulate[1] :RELAtive:FREQUency0[:DATA] <Numeric\_Value>[Hz]

Set the center frequency of relative operation.

6.3.2.5 :CALCulate[1] :RELAtive:LOWer[:DATA] <Numeric\_Value>[Hz]

Set the lower limit frequency of relative operation's difference.

6.3.2.6 :CALCulate[1] :RELAtive:UPPer[:DATA] <Numeric\_Value>[Hz]

Set the upper limit frequency of relative operation's difference.

6.3.2.7 :CALCulate[1] :LIMit:LOWer[:DATA] <Numeric\_Value>[Hz]

Set the lower limit frequency of limit judgment.

6.3.2.8 :CALCulate[1] :LIMit:UPPer[:DATA] <Numeric\_Value>[Hz]

Set the upper limit frequency of limit judgment.

6.3.3 :CALCulate2 Subcommand System

6.3.3.1 :CALCulate2:AVERAge:COUNt <Numeric\_Value>

Set the average time of average operation. The range of value is integer in 1-100.

6.3.3.2 :CALCulate2:AVERAge:[:STATe] <Boolean>

Open/close the average operation function. ON or 1 is to open, OFF or 0 is to close.

6.3.4 :MEASure Subcommand System

6.3.4.1 :MEASure:TYPE AUTO|MANUal|HIRSol

Set measurement mode: automatic measurement (AUTO), manual measurement (MANUal) or high-resolution measurement (HIRSol). Manual measurement can only be run in Channel B, high-resolution measurement can only be run in Channel A with the frequency range of 10Hz-80MHz.

6.3.4.2 :MEASure:MANUal:FREQUency0 <Numeric\_Value>[Hz]

Set the center frequency of manual measurement mode.

6.3.4.3 :MEASure:REFrence INT|EXT

Set the time base: INT is internal time base, EXT is external time base.

6.3.5 :INITiate Subcommand System

6.3.5.1 :INITiate:AUTO <Boolean>

Set and query: when conducting limit judgment, in case the measurement result surpasses the upper or lower limit, whether the frequency counter shall automatically stop or continue to measure. AUTO ON means that the frequency counter will automatically stop when the measurement result surpasses the upper or lower limit; AUTO OFF means that the frequency counter will continue to measure when the measurement result surpasses the upper or lower limit

#### 6.3.5.2 :INITiate:CONTInuous <Boolean>

Set and query the enabling state of frequency counter's continuous measurement. :INITiate:CONTInuous ON means that the frequency counter is in continuous measurement state, and will conduct the measurement immediately and start the next measurement after this measurement is completed. :INITiate:CONTInuous OFF means that the frequency counter is in single measurement state, it will stop after a single measurement and display the result.

#### 6.3.5.3 :INITiate[:IMMediate]

This command has only executive command but no query command. After receiving this command, the frequency counter will conduct a measurement immediately. But the measurement data won't be sent to interface.

#### 6.3.6 :INPut:FILTer[:LPASs][:STATe] <Boolean>

Set and query on-off state of low pass filter of Channel A with a frequency range of 10Hz-80MHz. ON or 1 is to open, OFF or 0 is to close.

#### 6.3.7 :MEASure? Subcommand

:MEASure?

Conduct a measurement by the frequency counter and receive the measurement result. It means to conduct a measurement immediately and read the measurement result. The frequency counter returns to the measurement result represented by ASCII character string.

#### 6.3.8 :READ? Subcommand

:READ?

Read the latest measurement result from the frequency counter. If the measurement result exists, the frequency counter will return to the measurement result represented by ASCII character string. If not, it won't return.

### 6.3.9 [:SENSe] Subcommand System

#### 6.3.9.1 [:SENSe]:FUNctIon[:ON] “[:][XNOnE:]FREQUency [1]”

Set the current channel as channel 1: channel A with a frequency range of 10Hz-80MHz. This command is invalid under high-resolution measurement mode.

#### 6.3.9.2 [:SENSe]:FUNctIon[:ON] “[:][XNOnE:]FREQUency 2”

Set the current channel as channel 2: channel A with a frequency range of 60MHz-3.2GHz. This command is invalid under high-resolution measurement mode.

#### 6.3.9.3 [:SENSe]:FUNctIon[:ON] “[:][XNOnE:]FREQUency 3”

Set the current channel as channel 3: namely the channel B. This command is invalid under high-resolution measurement mode.

#### 6.3.9.4 [:SENSe]:FUNctIon[:ON] “[:][XNOnE:]FREQUency:CHECK”

Set the frequency counter to automatic self-check measurement, and the measurement result is 10MHz.

#### 6.3.9.5 [:SENSe]:FREQUency:ARM 1Hz|10Hz|100Hz|1kHz|10kHz

Set the measurement resolution of frequency counter.

### 6.3.10 :SYSTem Subcommand System

#### 6.3.10.1 :SYSTem:COMMunicate:GPIB[:SELf]:ADDRes <Numeric\_Value>

Set and query the address of IEEE488 interface of frequency counter. The setting scope is interger in 1-30.

#### 6.3.10.2 :SYSTem:COMMunicate:SERial:TRANsmit:BAUD 2400|4800|9600|19200|38400

Set and query the communication baud rate of frequency counter’s RS232 interface or USB general serial interface.

#### 6.3.10.3 :SYSTem:COMMunicate:SERial:TRANsmit:PARity[:TYPE] EVEN|ODD|NONE

Set and query the communication check bit of frequency counter’s RS232 interface or USB general serial interface. EVEN is even check, ODD is odd check, NONE is no check.

#### 6.3.10.4 :SYSTem:KEY <Numeric\_Value>

This command has only executive command but no query command. Dispatching this command equals pressing corresponding key. <Numeric\_Value> is the key code. Its range of value is 0-23.

Keys and their corresponding key codes are shown in the following table:

Key	Key code	Key	Key code
[Single]	0	[Channel A]	9
[Run]	12	[Channel B]	21
[Rate]	1	[Time base internal/external]	10
[Resolution]	13	[Number]	22
[Average setting]	3	Auxiliary function key[time base]	2
[Frequency offset operation]	15	Auxiliary function key[Channel A]	5
[Relative measurement]	4	Auxiliary function key[Channel B]	8
[Manual/Automatic]	16	Menu key[F1]	11
[Limit judgment]	6	Menu key[F2]	14
[Save and recall]	18	Menu key[F3]	17
[System]	7	Menu key[F4]	20
[Local]	19	Menu key[F5]	23

### 6.3.10.5 :SYSTem:LOCal

Return the instrument to local state. It is valid only for RS232 general serial interface and USB general serial interface.

### 6.3.10.6 :SYSTem:MEASure:PAUSe <Numeric\_Value>[s]

Set and query the measurement pause time of frequency counter. The range of value is real number in 0.1-9.9. The number can have only a decimal place.

### 6.3.11 General Command

#### 6.3.11.1 \*IDN?

This command has only query command, querying the identification code of instrument.

Query return: ASCII character string: SALUKI SXXXX –XXG

The first term is the manufacturer code symbol

The second term is instrument model.

The third term is instrument's frequency measurement scope.

#### 6.3.11.2 \*RCL <Numeric\_Value>

Callout the stored parameter state of the instrument from the register. This command

has no query command. The range of value is integer in 1-9.

#### 6.3.11.3 \*RST

Reset command. Set the frequency counter to starting-up state. This command has no query command.

#### 6.3.11.4 \*SAV <Numeric\_Value>

Save the current parameter state to register. This command has no query command. The range of value is integer in 1-9.

## Chapter 7 Precautions and Maintenance

### 7.1 Error Handling

The instrument has a certain capability to handle errors.

- The error display of input value out of range
- The error display of insignificant current function key or no response.

### 7.2 Maintenance Precautions

- Large-scale CMOS integrated circuit and high-speed ECL circuit are applied to the instrument, preventing which from accidental damage, the electric iron with two-wire power cord is prohibited during maintenance. The housings of test instrument or other devices shall be well grounded.
- Hot-line work is not allowed when repairing and welding. Once the power line is connected with the instrument and the supply unit is running, the power line must be unplugged before welding.
- In general, it shall first troubleshoot the external and intuitive faults in reparation, such as open circuit, short circuit or inappropriately set parameters, etc, and then measure whether each group of voltage of the machine is normal or not. In case of normal voltage, check up if the quiescent point of the faulty part of circuit is normal or with faulty soldered joints.
- In overhauling, the oscilloscope or the multimeter pen shall contact the test point without touching near points to avoid the expanding of faults.
- If the cause of malfunction is not available, please do not hesitate to contact us for a timely removal of trouble.